

MODELING AND ANALYSIS OF COMPOSITE LEAF SPRING

Kollu Leela Sai Tulasi Devi, Karri Chakradhar Reddy, Gudavalli Sai Krishna, Kadali Venkata Kiran Prasad & Dr. A. Gopichand
Department of mechanical engineering, Swarnandhra College of Engineering & Technology,
Andhra Pradesh.

ABSTRACT

Leaf spring is the potential component for weight reduction in order to achieve high fuel efficiency and better ride characteristics. Favourable mechanical properties of composite materials such as light weight, high strength and corrosion resistance. The materials selected for leaf spring are AS4,T300 and silenka E-glass 1200tex composite materials which is more economical with similar mechanical and geometrical properties to the steel leaf spring .The design software SOLIDWORKS is used for 3D Modeling of leaf spring and analysis of leaf spring using ANSYS 17.0 static structural tool has been used of ANSYS .

In the project semi –elliptical leaf spring can be designed. The main objective is to find the equivalent stress, equivalent strain and total deformation in the composite leaf spring by applying static load on it. Different materials with different mechanical properties are considered for the static structural analysis.

1.1INTRODUCTION

Originally Leaf spring called laminated or carriage spring, a leaf spring is a simple form of spring, commonly used for the suspension in wheeled vehicles. It is also one of the oldest forms of springing, dating back to medieval times. . Sometimes referred to as a semi elliptical spring or cart spring, it takes the form of a slender arc-shaped length of spring steel of rectangular cross-section. The centre of the arc provides location for the axle, while tie holes are provided at either end for attaching to the vehicle body. For very heavy vehicles, a leaf spring can be made from several leaves stacked on top of each other in several layers, often with progressively shorter leaves. Leaf springs can serve locating and to some extent damping as well as springing functions. A leaf spring can either be attached directly to the frame at both ends or attached directly at one end, usually the front, with the other end attached through a shackle, a short swinging arm. The shackle takes up the tendency of the leaf spring to elongate when compressed and thus makes for softer springiness.

In now a day the fuel efficiency and emission gas regulation of automobiles are two important issues. To fulfil this problem the automobile industries are trying to make new vehicle which can provide high efficiency with low cost. The best way to increase the fuel efficiency is to reduce the weight of the automobile. The weight reduction can be achieved primarily by the introduction of better material, design optimization and better manufacturing processes. The achievement of weight reduction with adequate improvement of mechanical properties has made composite a very good replacement material for conventional steel.

In automobile car out of many components one of the components of automobile which can be easily replaced is leaf spring. A leaf spring is a simple form of spring, commonly used for the suspension in wheeled vehicles. The suspension of leaf spring is the area which needs to focus to improve the suspensions of the vehicle for comfort ride. The suspension leaf spring is one

of the potential items for weight reduction in automobile as it accounts for 10 to 20% of unsprung weight.

SPRINGS

It is well known that springs, are designed to absorb and store energy and then release it. Hence, the strain energy of the material becomes a major factor in designing the springs.

1.3.1 TYPES OF SPRINGS

- Leaf Springs
- Helical Springs
- Torsion Springs
- Disc or Belleville Springs
- Conical & Volute Springs

LEAF SPRING

A spring is defined as an elastic body, whose function is to distort when loaded and to recover its original shape when the load is removed. Springs are elastic bodies that can be twisted, pulled or stretched by some force. They can return to their original shape when the force is released. Leaf spring (also known as flat springs) is made out of flat plate. The advantage in leaf spring over helical spring is that the ends of the spring may be guided along a definite path as it deflects to act as a structural member in addition the energy absorbing device. Thus the leaf springs may carry lateral loads, brake torque, driving torque etc., in addition to shocks. Single plate fixed at one end and loaded at the other end. This plate may be used as a flat spring.



Figure 1. Manufactured Leaf Spring

2. SELECTION OF MATERIALS

2.1 MATERIAL FOR LEAF SPRING

The material used for leaf springs is usually a plain carbon steel having 0.90 to 1.0% carbon. The leaves are heat treated after the forming process. The heat treatment of spring steel produces greater strength and therefore greater load capacity, greater range of deflection and better fatigue properties.

Materials constitute nearly 60% -70% of the vehicle cost and contribute to the quality and the performance of the vehicle. Even a small amount in weight reduction of the vehicle, may have a wider economic impact. Composite materials are proved as suitable substitutes for steel in connection with weight reduction of the vehicle. Hence, the composite materials have been selected for leaf spring design.

The material of the spring should have high fatigue strength, high ductility, high resilience and it should be creep resistant. It largely depends upon the service for which they are used i.e. severe service, average service or light service.

Severe service means rapid continuous loading where the ratio of minimum to maximum load (or stress) is one-half or less, as in automotive valve springs. Average service includes the same stress range as in severe service but with only intermittent operation, as in engine governor springs and automobile suspension springs. Light service includes springs subjected to loads that are static or very infrequently varied, as in safety valve springs.

3.1 DESIGN OF COMPOSITE LEAF SPRING

Modelling of leaf spring is performed in solidworks 2015 software. Procedure for modeling of leaf spring is as follows:

There are different procedures available for modeling of leaf spring. Here we utilized divisional method of generation of semi-elliptical leaf spring.

1) Create the sketch with the help of leaf spring with length and camber. Divide leaf spring length and camber into equal division and draw a spline which passes through intersection of camber and length division.

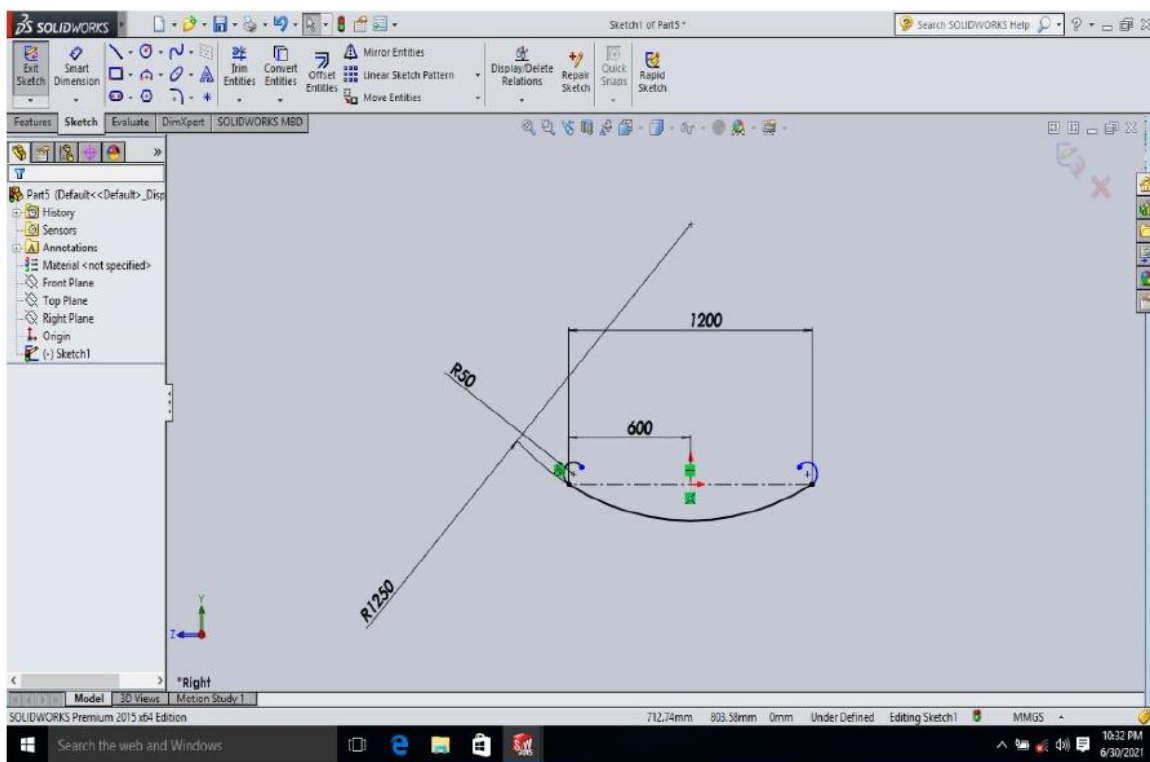

FIG 5.1 SKETCH OF MASTER LEAF

2) Extrude above sketch to leaf spring width to create one leaf.

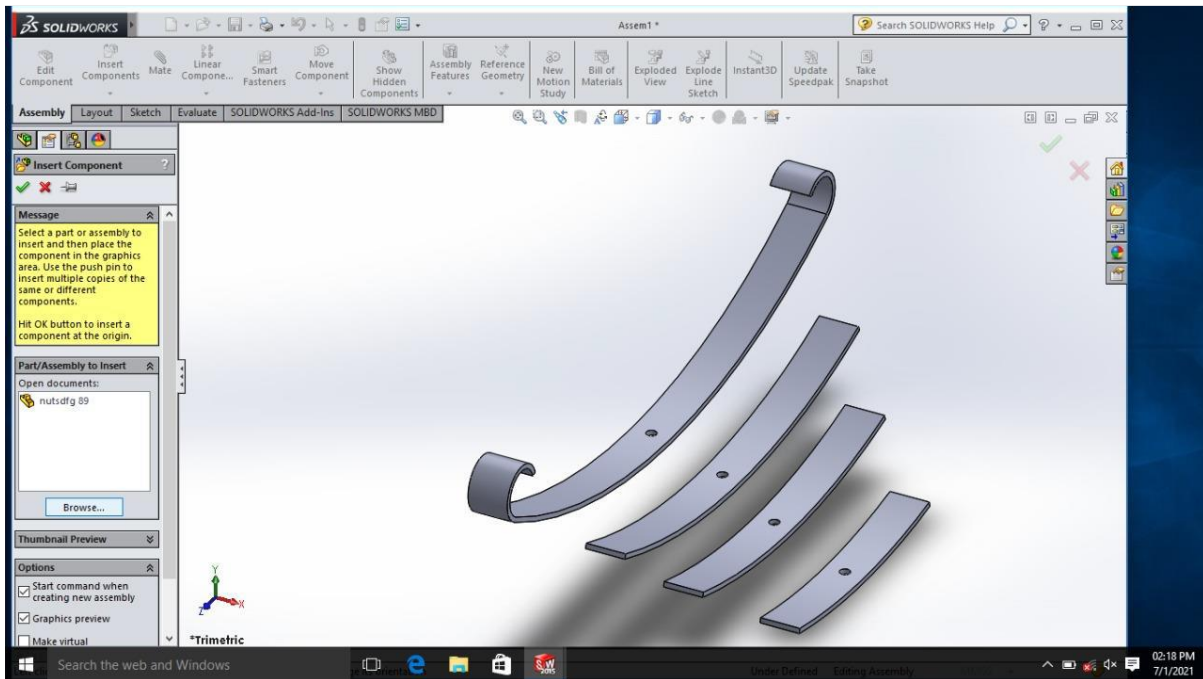

FIG 5.3 ISOMETRIC VIEW OF LEAFS

3) Same way create four leaves for generating leaf spring.

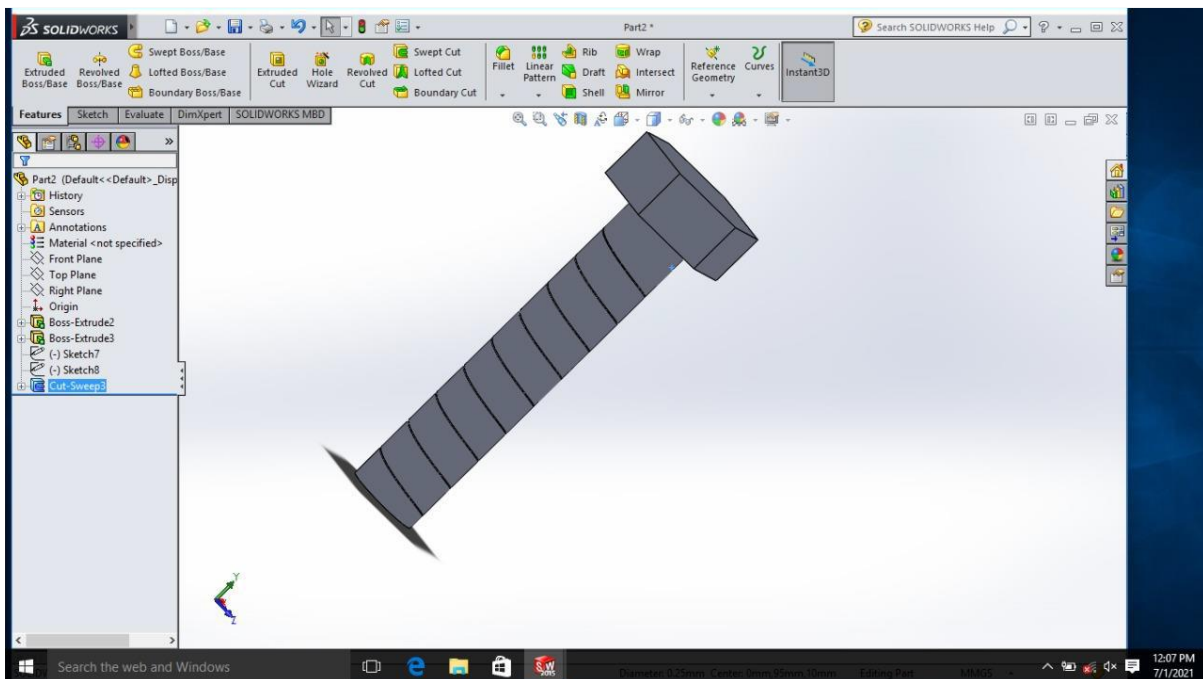

FIG 5.4 ISOMETRIC VIEW OF BOLT

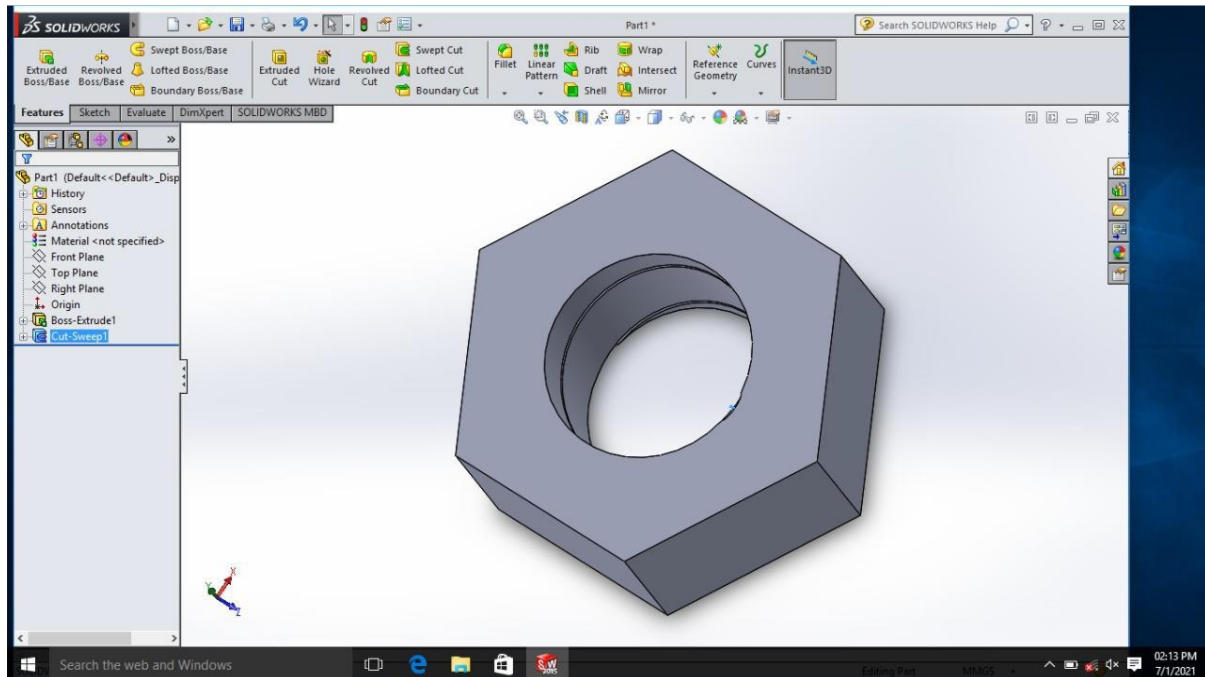

FIG 5.5 ISOMETRIC VIEW OF NUT

Sketch a circle on the other side of the head with a diameter of 20 mm, then click OK.

2. On Feature, click on Extrude boss.

3. Select the top plane and draw the polygon and extrude boss.

4. At top left corner, click on Feature, then choose Curve>Helix and Spiral.

5. On the Helix window feature, define the helix by Height and Revolution.

After finishing this step, your bolt should look same as the picture shown above

4. Select the top plane and sketch the polygon, Give Extrude boss option it as per the dimensions.

Select the top plane, Draw the circle with diameter 20mm and make extrude cut.

4. ANALYSIS OF COMPOSITE LEAF SPRING

Geometry

On Static Structural Module, Right Click on Geometry then Click on Edit Geometry on Design Modular. Click on file then click, Import External Geometry File and Select the .STEP file in the browsing Window. Then Click on Generate. The Modeling of leaf spring Now visible in Design Modular. Then Exit the Design Modular, Then the Static Structural Module will look like this. The Green Tick indicates that the Solidworks model is successfully generated in Design modler.

Model

Double Click on Model a new Static Structural-Mechanical window will open. Firstly select the material for that you want to do the analysis by clicking on the leaf spring you have imported.

Meshing

The model and breaks down into small pieces called finite “elements”. This process is called “meshing”. Higher the quality of the mesh enhanced the mathematical representation of the physical model. After Meshing the leaf spring has generated 1382 Elements and 3088 Nodes.

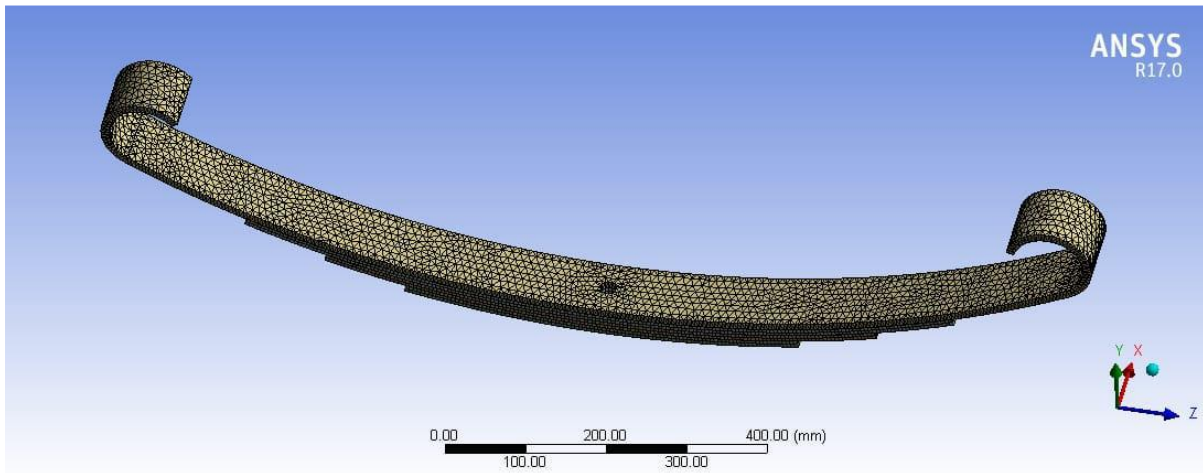

FIG 4.1 MESHING

After Meshing Fixed Support is given at 3 sides

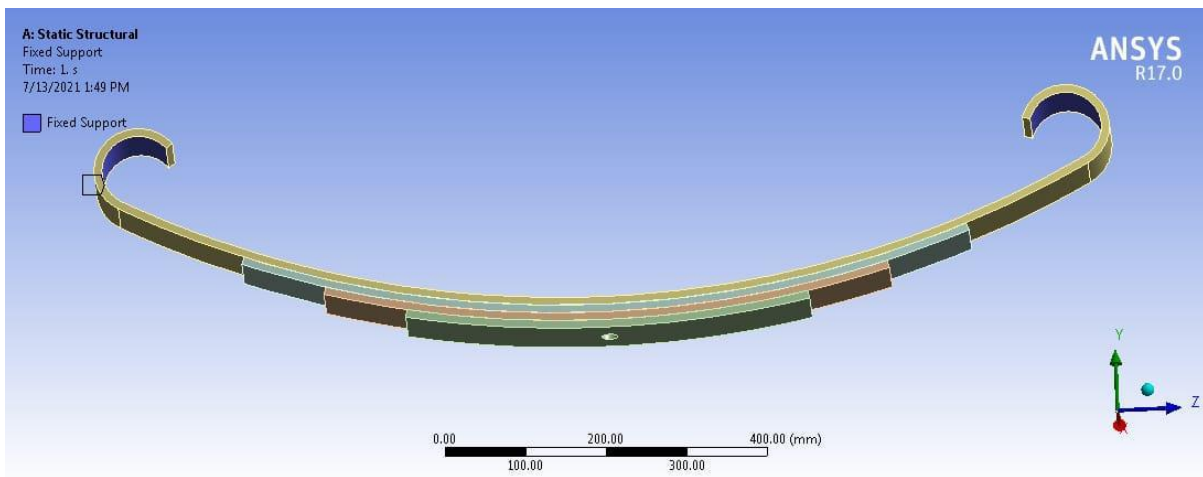

FIG 4.2 FIXED SUPPORTS

Loading

Load applied on the center of the leaf spring [upward direction]

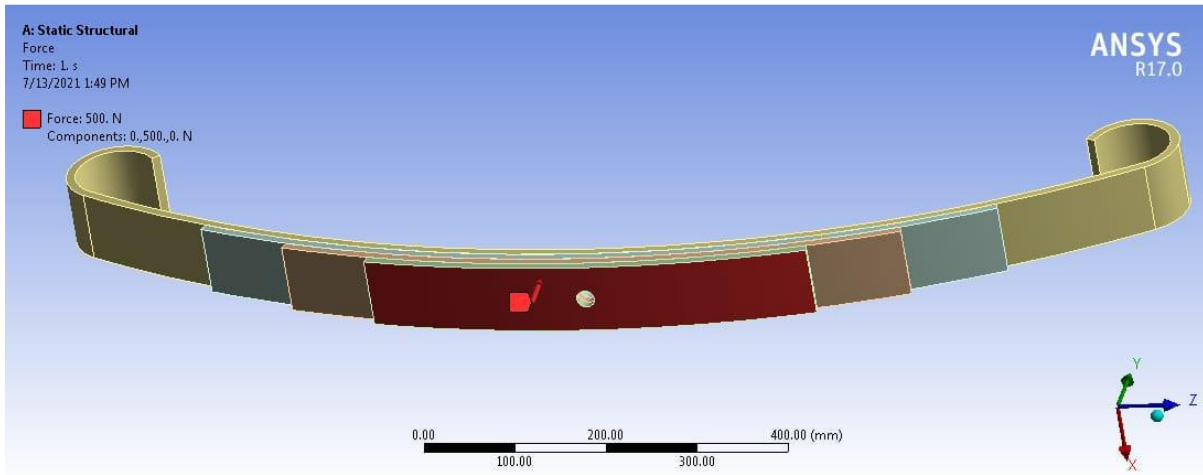

FIG 4.3 LOADING

Structural analysis of composite leaf spring
MATERIAL1 :AS4

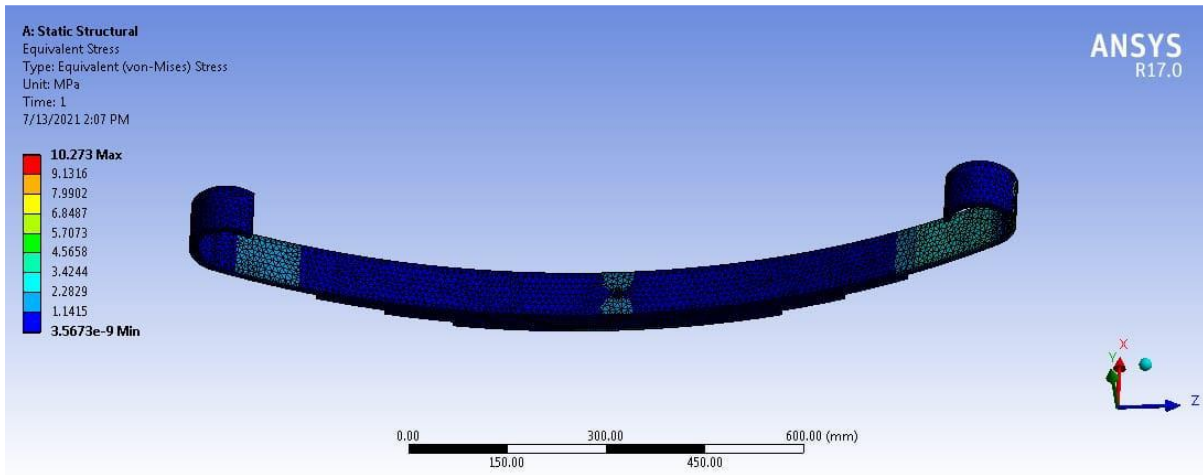

FIG 4.3 EQUIVALENT (VON-MISES) STRESS FOR AS4

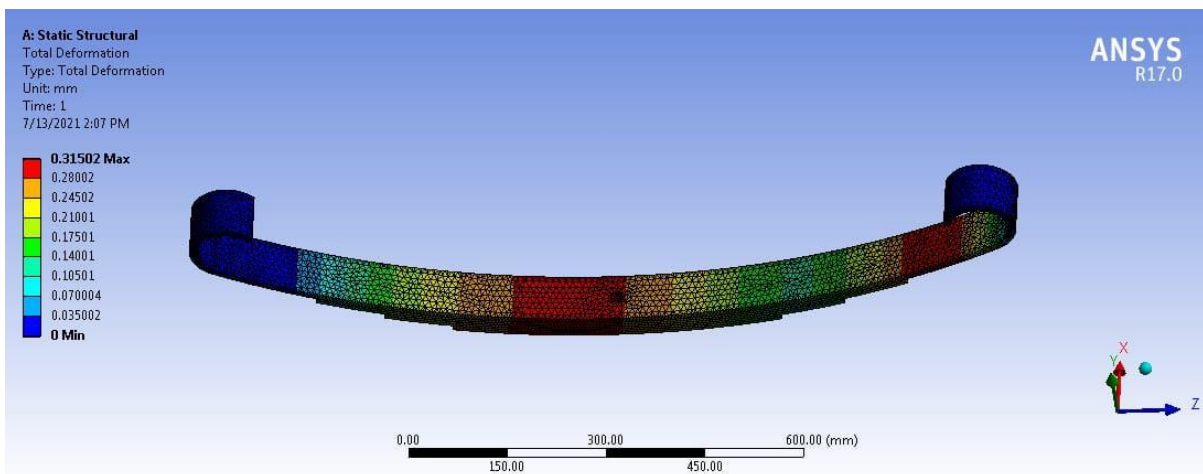

FIG 4.5 TOTAL DEFORMATION FOR AS4

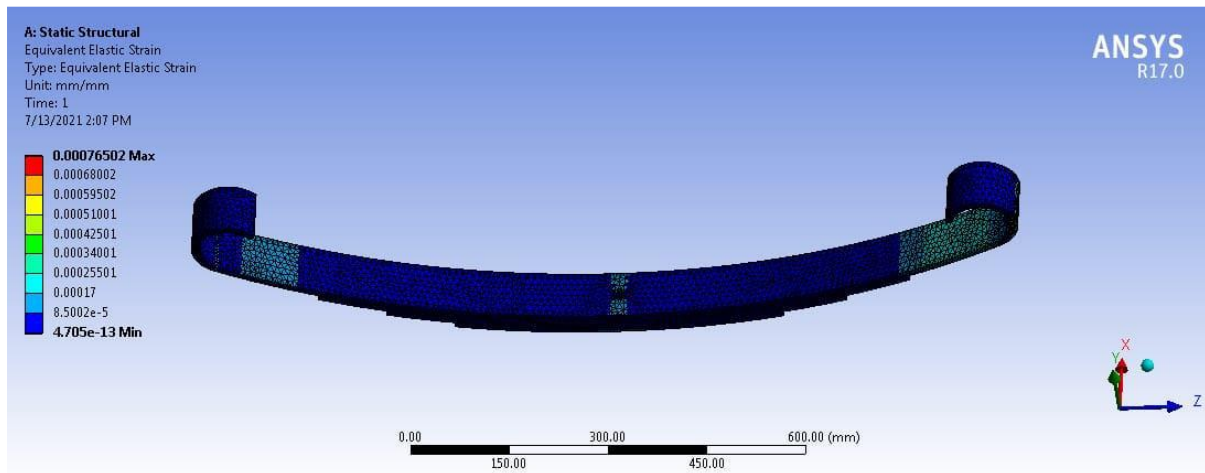

FIG 4.6 EQUIVALENT (VON-MISES) STRAIN FOR AS4

5 Results:

We have taken three materials namely AS4, T300 and SILENKA E-GLASS 1200tex and applied the same load, for those loads the Equivalent stress, Total deformation and Equivalent strain and they are tabulated as flows.

5.1 Table :Comparison of Equivalent stress, Total deformation, Equivalent strain

S.no	Materials	Equivalent stress	Total deformation	Equivalent strain
1	AS4	10.273	0.31502	0.00076502
2	T300	9.9570	0.50755	0.0012
3	SILENKA E-GLASS 1200tex	10.175	0.2874	0.000732

CONCLUSION

Composite leaf spring is analysed with different type of materials by using finite element analysis. From the analysis we found the maximum equivalent stresses, total deformation and equivalent strain of AS4, T300 and SILENKA E-GLASS 1200tex. It is observed that minimum equivalent stresses, total deformation and equivalent strain In material like SILENKA E-GLASS 1200tex is low so the SILENKA E-GLASS 1200tex is best material.

REFERENCE

- 1.Pankaj Saini, Ashish Goel, Dushyant Kumar, “Design and analysis of composite leaf spring for light vehicles”, International Journal of Innovative Research in Science, Engineering and Technology, Vol. 2, Issue 5, May 2013.
2. Mahmood M. Shokrieh, Davood Rezaei, “Analysis and optimization of a composite leaf spring”, Composite Structures 60 (2003) 317–325.
3. M.Venkatesan, D.Helmen, “Design and analysis of composite leaf spring in light vehicle”, International Journal of Modern Engineering Research, Vol.2, Issue.1, 2012, pp 213-218.

4. GulurSiddaramanna Shiva Shankar, SambagamVijayarangan, “Mono Composite Leaf Spring for Light Weight Vehicle – Design, End Joint Analysis and Testing”, Materials science (medžiagotyra), Vol. 12, No. 3, 2006.
5. Mouleeswaran Senthil Kumar, SabapathyVijayarangan, “Analytical and Experimental Studies on Fatigue Life Prediction of Steel and Composite Multi-leaf Spring for Light Passenger Vehicles Using Life Data Analysis”, Materials science (medžiagotyra), Vol. 13, No. 2, 2007.
6. K. K. Jadhao, DR. R. S. Dalu, “Experimental investigation & numerical analysis of composite leaf spring”, International Journal of Engineering Science and Technology, Vol. 3, No. 6, 2011.
7. Kumar Krishan, Aggarwal M.L, “Computer aided FEA coMParison of mono steel and mono GRP leaf spring”, International Journal of Advanced Engineering Research and Studies, Vol. I, Issue II, 2012, pp 155-158.
8. Joo-teck Jeffrey, Tarlochan Faris, “Finite element analysis on the static and fatigue characteristics of composite multi-leaf spring”, Journal of Zhejiang UniversityScience, Vol. 13, 2012, pp 195-164
9. N. P. Dhoshi, Prof. N. K. Ingole, Prof. U. D. Gulhane, “Analysis and modification of leaf spring of tractor trailer using analytical and finite element method”, International Journal of Modern Engineering Research, Vol.1, Issue.2, pp 719-722.
10. M. M. Patunkar, D. R. Dolas, “Modelling and Analysis of Composite Leaf Spring under the Static Load Condition by using FEA”, International Journal of Mechanical & Industrial Engineering, Volume 1, Issue 1, 2011.
11. M Senthil Kumar, S Vijayarangan, “Static analysis and fatigue life prediction of steel and composite leaf spring for light passenger vehicles”, Journal of Scientific & gnu.inflibnet.ac.in 66 Industrial Research, Vol. 66, 2007, pp 128-134.