

# **Design and Analysis of Roller with Coil Lifter for Heavy Coil Wrapping Machine**

Rudra Nanadan Pramanik<sup>1</sup>, Nabnit Panigrahi<sup>2</sup>, Premananda Rana<sup>3</sup>  
<sup>1, 2</sup>Asst. Professor, <sup>3</sup>Student

Department of Mechanical Engineering  
Einstein Academy of Technology and Management  
Bhubaneswar, Khurda, Odisha, India

## **ABSTRACT**

Rolling mill is used roll aluminum sheets into heavy coils. This is also called as end coils. These Aluminum coils must be protected from dust, moisture and damages which may occur while transportation, loading and unloading of the material. This unwanted situation can be prevented by wrapping with proper material like HDPE and Poly ethylene film over the surface circumferentially. This will preserve the same surface finish and quality that is obtained after rolling the coil. This paper gives an idea to design and develop a roller with coil lifter for heavy coil wrapping machine. This will rotate the coil at a desired speed to wrap a desired wrapper material over the coil surface circumferentially. After the completion of wrapping process the lifter will lift the coil, then transfer it to roller conveyer. AutoCAD 2012 tool is used for 2D drawings of roller with coil lifter which consists of General Assembly (G.A.), Sub-assembly and Part Drawings. Solid Works 2013 tool is used for 3D modeling of roller with coil lifter. Motion Simulation is also carried out on assembly which shows the operation of the machine using Solid-works2013 tool. The coil load is directly acting on the rollers of the roller assembly, while lifting the coil load will be acting on the lifter. Analysis is done to check for safer design which should withstand the applied loads on the parts. The result obtained is compared with the values obtained from numerical method.

**Keywords:** Solid Works 2013, Aluminum, HDPE, AutoCAD 2012.

## **1. INTRODUCTION**

The packing of product in a scientific manner, place an important role in the industries. But at the same time industries are facing many problems, regarding the fund generation for the high operational efficiency for the high rate of wrapping process using conventional wrapping methods.

The rejection of products at the time of deliver has been increased in this decade due to improper or unscientific method of wrapping the products. This is due to lack of man power, difficulty in getting assured amount of returns with respect to investments and shortage of time. The coil wrapping machine is a new concept in the current world, in which the coil protector is used for wrapping and packaging of products like: HDPE and Polythene film, in this process of packing we can achieve less total investment in the packing area.

From the past few decades the engineers are continuously working on the finished products and material handling in the field of coil product wrapping. Traditionally horizontal position wrapping machine has been used for wrapping the products through the coil eye. The wrapping machine of 1990 “decade model machines are of automatic wrapping type with huge piece of machineries and this type of wrapping coil protector has been outdated and no longer meet today’s demand.

The wrapping machine offers flexibility over traditional coil protector. The wrapping protector is more flexible right from semiautomatic to fully automated multistage coil

wrapping machine. While selecting the wrapping machine the following points must be considered for selecting the machine type. The consideration not only packing the products itself, but also the man power availability, product size, shape and its density and also floor space availability in the industry.

The packing process is mainly divided into two stages, first is the moisture protection and second is the mechanical protection. In the first moisture protection stage the final product is protected from moisture that is humidity present in the atmosphere and from the rustformationduetochemicalreactionbetweentheproductandtheoutsideatmosphereinpresence of oxygen and moisture contents in the air. The product is also protected from mechanical shocks like sudden and impact shock loads on the material during transportation off in shed products and material handling during storage.

## **2. DESIGN AND DEVELOPMENT**

### **2.1. Introduction**

The roller with coil lifter is the sub assembly of the heavy coil wrapping machine which consists of supporting legs, main frame, roller with sprockets, pneumatic cylinder assembly and geared motor. The supporting legs of this sub assembly give structural support to all the components which are mentioned above. The frame will be fixed on the supporting legs and rollers with sprocket are fixed above the frame. This sub assembly consists of six sprockets which will be connected to rollers and the rolled aluminium coil will placed on the rollers. The coil lifter assembly consists of pneumatic cylinder and the cylinder accessories and a supporting let and two MS rod to avoid the wobbling of the cylinder while lifting the aluminium coil after wrapping.

### **2.2. 2DDrawingsofRollerwithCoilLifter**

The 2 dimensional drawing of the roller with coil lifter is drawn with the help of drafting tool auto CAD-2012. The below figures show the conceptual 2-dimension drawings of roller with coil lifter.

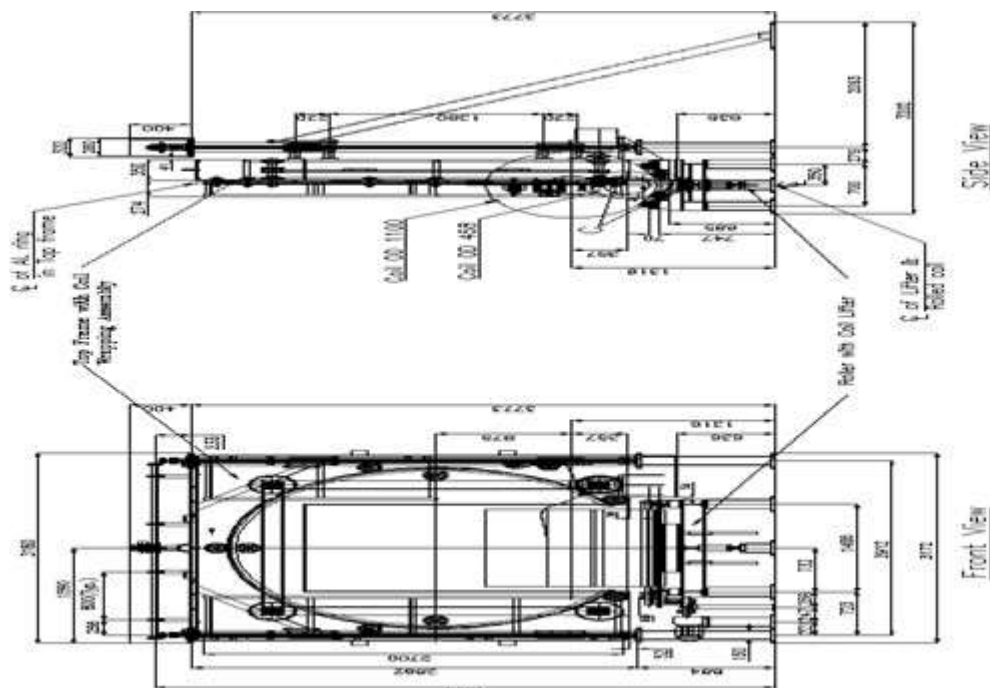

**Figure1** General Assembly of heavy coil wrapping machine

### 2.3. Dimensional Modelling

The 3-dimension modelling of the roller and coil lifter is modelled by using solid works-2013 tool. The following figures show the 3-dimensional modeling of roller with coil lifter.

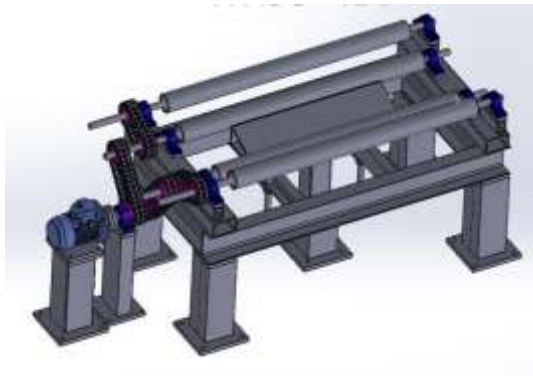

Figure 2 3-D Modeling of roller with coil lifter wrapping machine

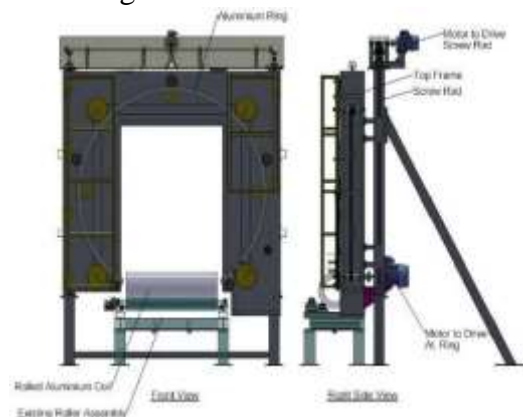

Figure 3 General Assembly of heavy coil

## 3. MOTION SIMULATION AND ANALYSIS

### 3.1. Motion Simulation of Roller System

In this study the motion simulation of rollers carried to show how the rollers are rotated to roll the aluminium coil to complete the wrapping process. After completing of assembly part the motion simulation is carried out.

Size constraint of the rolled coil is 1100 mm outer diameter, 300 mm inner diameter and 1300 mm width, aluminium ring diameter depends on this size constraint. Each coil has to be wrapped in around 2.5 to 3 minutes. Since the aluminium ring will be rotating at 40 rpm the rolled aluminium coil has to rotate at 0.74 rpm. To obtain the requirements the rollers has to be rotate at 9.06 rpm and to obtain this speed the Boniglioli make C type geared motor is selected which is of 0.55Kw and rotate at a speed of 23.5rpm.

As the size of the coil decreases the rolled coil speed will change. Since the speed of the aluminium ring is constant the speed of the rollers also remains same. To rotate the rollers chain and sprocket system is adopted.

Initially motor speed and direction of rotation will be defined in the solid works motion study. Once the values are defined, the processor will start calculating the required values for motion simulation to the give constrains. Then finally the motion simulation the component starts.



Figure4 Motionsimulationofroller

## 4. RESULTS AND DISCUSSION

The geometric modeling of the main frame of the roller assembly has been created using solid works V-2013 and the model has been meshed using the same tool.

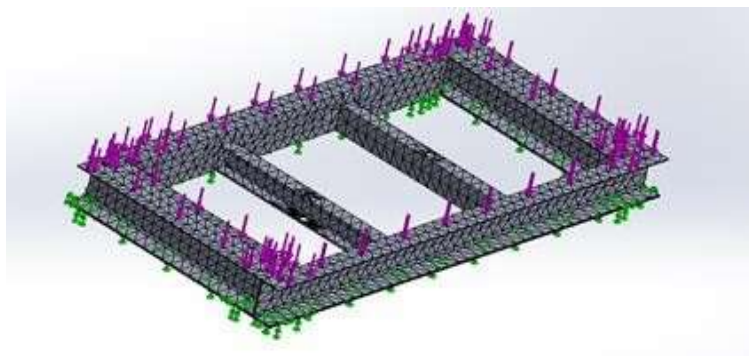

Figure5 Finite element meshed model of the main frame

### 4.1. Stress Analysis of Main Frame of Roller Assembly

The main frame is designed for providing the structural support to the rollers and rest of the components. The stress analysis has been carried out using solid works V-2013 tool. The load of 4480 N is applied along „Y“ direction to determine the stress in the main frame structure. The maximum stress is found to be 3.285 MPa and minimum stress was recorded around 0.0000439 MPa and the yield strength of the material found to be 250 MPa (MS). Since the value of the stress obtained is less than that of the yield strength of the material and hence the design of the main frame of roller assembly is safe.

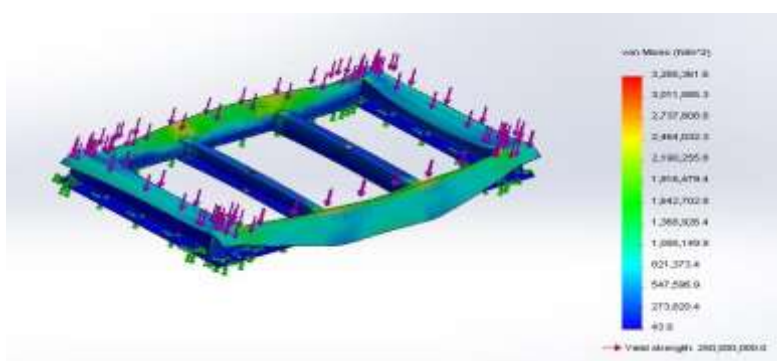

Figure6 Stress analysis of the mainframe

### 4.2. Deformation of Main Frame of Roller Assembly

The main frame is designed for providing the structural support to the rollers and rest of the components. The structural deformation has been carried out using solid works V-2013 tool. The load of 4480 N is applied along „Y“ direction to determine the deformation in the mainframe structure. The maximum deformation is found to be  $2.257e^{-2}$  mm and minimum deformation was recorded around  $1.00e^{-30}$  mm and the deformation of the material is found to be 3.34mm (MS). Since the value of the deformation obtained is within the allowable limits of the material and hence the design of the main frame of roller assembly safe.

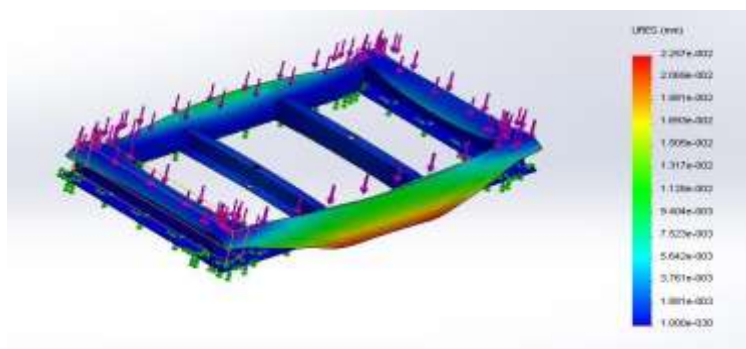

Figure7 Deformation of the main frame

### 4.3. Strain Analysis of Main Frame of Roller Assembly

The main frame is designed for providing the structural support to the rollers and rest of the components. The strain analysis has been carried out using solid works V-2013 tool. The load of 4480 N is applied along 'Y' direction to determine the strain in the main frame structure. The maximum strain is found to be  $1.055e^{-5}$  and minimum strain was recorded around  $4.135e^{-10}$  and the yield strength of the material found to be  $1.1903e^{-3}$  (MS). Since the value of the strain roller assembly is safe.

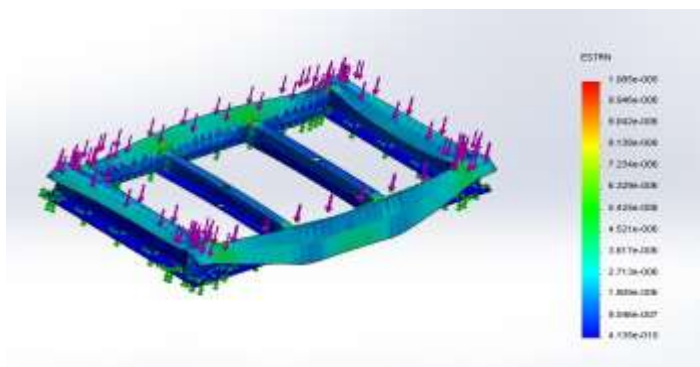

Figure8 Strain analysis of the mainframe

### 4.4. Finite Element Meshed Model of Roller

The geometric modeling of roller has been created using solid works V-2013 and the model has been meshed using the same tool.

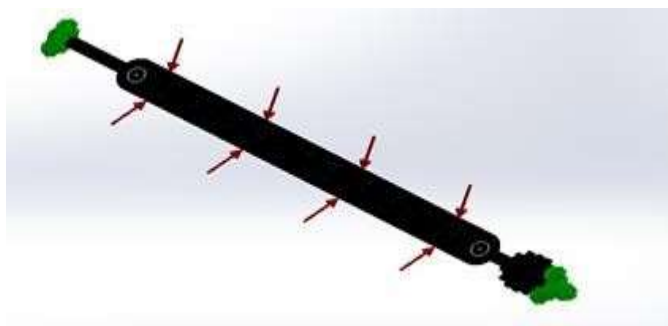

Figure7 Finite element meshed model of roller

### 4.5. Stress Analysis of the Roller (maximum load)

The roller is designed for providing the support to the Aluminium coil. The stress analysis has been carried out using solid works V-2013 tool. The load of 4000 N is applied along 'Y' direction to determine the stress in the main frame structure. The maximum stress is found to be 42.6 MPa and minimum stress was recorded around .01 MPa and the yield strength of the material found to be 250 MPa (MS). Since the value of the stress obtained is less than that of the yield strength of the material and hence the design of the main frame of roller assembly is safe.

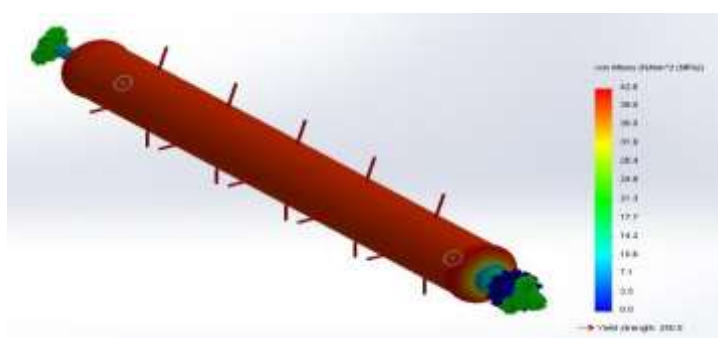

Figure8 Stress analysis of roller

#### 4.6. Deformation of Main Frame of Roller Assembly

The roller is designed for providing the support to the Aluminium coil. The structural deformation has been carried out using solid works V-2013 tool. The load of 4000 N is applied along „Y“ direction to determine the deformation in the main frame structure the maximum deformation is found to be  $1.530e^{-2}$  mm and minimum deformation was recorded around  $1.00e^{-30}$  mm and the deformation of the material is found to be 3.34mm (MS). Since the value of the deformation obtained is within the allowable limits of the material and hence the design of the main frame of roller assembly is safe.

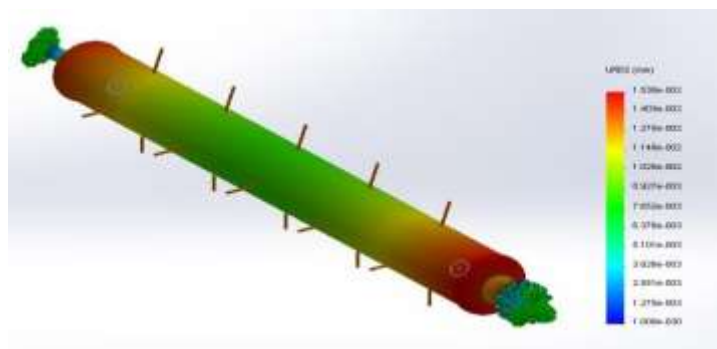

Figure9 Deformation of roller

#### 4.7. Strain Analysis of Main Frame of Roller Assembly

The roller is designed for providing the support to the Aluminium coil. The Strain analysis has been carried out using solid works V-2013 tool. The load of 4480 N is applied along ‘Y’ direction to determine the strain in the main frame structure. The maximum strain is found to be  $1.747e^{-4}$  and minimum stress was recorded around  $6.494e^{-9}$  and the yield strength of the material found to be  $1.1903e^{-3}$  (MS). Since the value of the strain obtained is less than that of the strain of the material and hence the design of the main frame of roller assembly is safe.

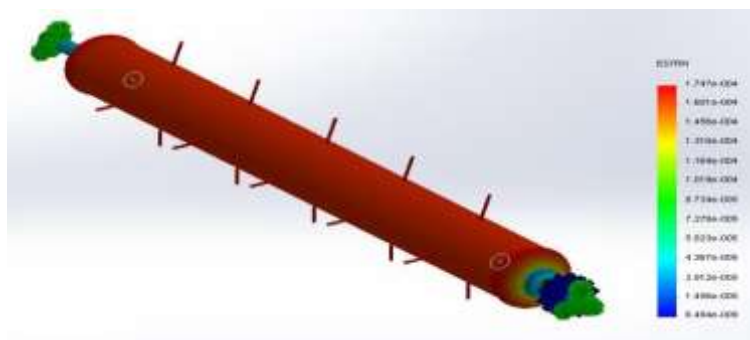

Figure10 Strain analysis of roller

### 5. CONCLUSIONS

- The roller with coil lifter is developed for wrapping of finished goods and the basic 2 dimensional conceptual drawing has been drawn using auto-CAD V-2012 and 3 dimensional model using solid works V-2013.
- The main frame is designed for providing the structural support to the rollers and rest of the components. The maximum stress is found to be 3.285 MPa and minimum stress was recorded around 0.0000439 MPa and the yield strength of the material found to be 250 MPa (MS). Since the value of the stress obtained is less than that of the yield strength of the material and hence the design of the main frame of roller assembly is safe.

- Design, Development, Motion Simulation and Analysis of Roller with Coil Lifter for Heavy Coil Wrapping Machine
- The roller is designed for providing the support to the Aluminium coil. The maximum stress is found to be 42.6 MPa and minimum stress was recorded around .01 MPa and the yield strength of the material found to be 250 MPa (MS). Since the value of the stress obtained is less than that of the yield strength of the material and hence the design of the main frame of roller assembly is safe.
- Initially the production rate was 4 coils/hour and after introducing the automating wrapping machine the production rate has been increased to 15 coils/hour.
- The overall production rate has been increased and thus reduction in production cost and labor cost.

## **REFERENCE**

- [1] D. Kanimozhi, B. Nantheni Devi and T. Manochandar “PLC Controlled Automatic Food Packaging Machine”, International Journal of Engineering Trends and Technology (IJETT) –Volume 30 Number1-December2015, pp33-36.
- [2] Suraj S. Nair, Suraj D. Mankar and Anuradha D. Jadhav “Automatic Wrapping Machine”, International Journal of Engineering Trends and Technology (IJETT)– Volume31Number5-January2016, pp 228-231.
- [3] AlhadeA Algitta, Mustafa S, Ibrahim F, Abdalruof N and Yousef M “Automated Packaging Machine Using PLC”, International Journal of Innovative Science, Engineering & Technology, Vol. 2 Issue5, May2015, pp 282-288.
- [4] Kate-Deshmukh N S and Gaikwad M U “Design, Analysis and Testing of shaft mounted speed reducer for coil winding machine”, International Research Journal of Engineering and Technology, Volume:03 Issue:01,Jan-2016, pp546-554.
- [5] Abhishek C Lad and A S Rao “Design and Drawing Automation Using Solid works Application Programming Interface ”, International Journal of Emerging Engineering Research and Technology, Volume 2, Issue 7, October2014, PP157-167.
- [6] Imran S. Khan and Prof. Ravindra Gandhe “Study and Analysis of Roller Conveyor in Material Handling”, International Journal of Engineering Sciences and Research–Technology, ISSN: 2277-9655 (I2OR), Publication Impact Factor: 3.785, pp 724-728, 2015.
- [7] Dhiraj P Sanghavi, Prof. D B Sadaphale and Pratik k Satav “Analysis of roller of roller gravity conveyor and validation”, International Journal of Innovative Research in Technology, Volume 1 Issue 10, ISSN: 2349-6002, pp 95-97, 2014.
- [8] Jagtap M D, Gaikwad B D and Pawar P M “Study of Roller Conveyor Chain Strip under Tensile Loading”, International Journal Of Modern Engineering Research, Volume4, Issue 5, May2014, pp 6-66.
- [9] Mohyuddin Javaliya and V.P. Prajapati “Experimental Study of Performance Characteristics of Two Wheeler By Changing Final Drive Gear Ratio”, International Journal for Scientific Research & Development, Vol. 2, Issue 03, ISSN (online): 2321-061, pp756-758, 2014.
- [10] Ming-Hung Tsai, Chi-Neng Cheng and Ming-Chang Shih “Design and Control for the Pneumatic Cylinder Precision Positioning under Vertical Loading”, Department of Mechanical Engineering, National Cheng Kung University, Tainan, Taiwan, R.O.C.
- [11] Dr Ravi Kumar Goyal, A nuragJoshi and Umesh Gurnani, Comparison of Roll Deformation In 4hi Rolling Mill and 20 Hi Rolling Mill Due To Thermal Stresses, Overloading, Spalling and Design Parameters. International Journal of Design and Manufacturing Technology 7 (1), 2016, pp. 07 -22.
- [12] Nilam K. Wankhade and Dhananjay. R. Ikhhar, Design and Analysis of Axial Crossing of Work Rolls in Rolling Mill Work Roll Assembly: A Review. International Journal of Mechanical Engineering and Technology, 7(2), 2016, pp. 191– 195.