

ADAPTIVE PI CONTROL OF STATCOM FOR VOLTAGE REGULATION

^{#1}CHEEPURI RAVITEJA, *M.Tech Student, Department of EEE,*

^{#2}N.S.KALYAN CHAKRAVATHI, *Assistant Professor & HOD, Department of EEE,*

KAKINADA INSTITUTE OF TECHNOLOGICAL SCIENCES (KITS), KAKINADA, AP.

ABSTRACT:

In power systems, voltage instability problems occur due to its continuous demand in heavily loaded networks. So it is essential to stabilize the voltage levels in power systems. The stabilization of power systems can be improved by Flexible Alternating Current Transmission System (FACTS) devices. One of the FACTS devices named Static Synchronous Compensator (STATCOM) injects the compensating current in phase quadrature with line voltage and replicate as inductive reactance to produce capacitive power for the AC grid or as capacitive reactance to draw inductive power from the AC grid for controlling power flow in the line. This paper proposes Adaptive PI control over conventional PI that normally self-adjusts the controller gains under disturbances and helps in improving the performance and attaining a preferred response, irrespective of the change of working conditions. The work is implemented under MATLAB/SIMULINK environment. This method performs more efficient than the original PI with fixed control gains and also improves the system response speed consistently.

Keywords: Adaptive control; Proportional Integral (PI) control; Reactive Power; STATCOM; Voltage stability.

1. INTRODUCTION

The control logic is implemented with the fuzzy controllers. The control parameters or gains play a key factor in STATCOM performance. Presently, few studies have been carried out in the control parameter settings. In [10]–[12], the PI controller gains are designed in a case-by-case study or trial and-error approach with tradeoffs in performance and efficiency. Generally speaking, it is not feasible for utility engineers to perform trial-and-error studies to find suitable parameters when a new STATCOM is connected to a system. Further, even if the control gains have been tuned to fit the projected scenarios, performance may be disappointing when a considerable change of the system conditions occurs, such as when a line is upgraded or retires from service [13], [14].

The situation can be even worse if such transmission topology change is due to a contingency. Thus, the STATCOM control system may not perform well when mostly needed. A few, but limited previous works in the literature discussed the STATCOM PI controller gains in order to better enhance voltage stability and to avoid time consuming tuning. For instance, in [15]–[17], linear optimal controls based on the

linear quadratic regular (LQR) control are proposed. This control depends on the designer's experience to obtain optimal parameters. In [18], a new STATCOM state feedback design is introduced based on a zero set concept. Similar to [15]–[17], the final gains of the STATCOM state feedback controller still depend on the designer's choice. In [19]–[21], a fuzzy control method is proposed to tune PI controller gains.

However, it is still up to the designer to choose the actual, deterministic gains. In [22], the population based search technique is applied to tune controller gains. However, this method usually needs a long running time to calculate the controller gains. A tradeoff of performance and the variety of operation conditions still has to be made during the designer's decision-making process. Thus, highly efficient results may not be always achievable under a specific operating condition.

Different from these previous works, the motivation of this paper is to propose a control method that can ensure a quick and consistent desired response when the system operation condition varies. In other words, the change of the external condition will not have a negative impact,

such as slower response, overshoot, or even instability to the performance. Base on this fundamental motivation, an fuzzy control of STATCOM for voltage regulation is presented in this paper. With this fuzzy control method, the fuzzy control parameters can be self-adjusted automatically and dynamically under different disturbances in a power system.

When a disturbance occurs in the system, the control parameters for STATCOM can be computed automatically in every sampling time period and can be adjusted in real time to track the reference voltage. Different from other control methods, this method will not be affected by the initial gain settings, changes of system conditions, and the limits of human experience and judgment. This will make the STATCOM a “plug-and-play” device. In addition, this research work demonstrates fast, dynamic performance of the STATCOM in various operating conditions.

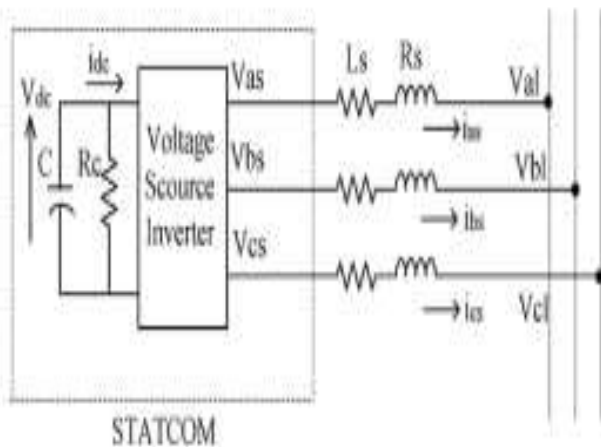

Fig. Equivalent circuit of STATCOM

2. LITERATURE SURVEY

Y. Han, Y. O. Lee [5] presents about Modified non-direct damping of inward progression by means of criticism linearization for static synchronous compensator. The info yield linearization by means of criticism has been connected to STATCOM and it demonstrates uniform transient execution yet attributable to softly damped interior flow it brings about current swells in DC-side capacitors. To diminish the swells, a damping term, time subsidiary of dynamic current duplicated by a consistent pick up, was added to the information yield linearization. An altered non-direct damping controller is proposed to enhance the restriction. The proposed strategy has the damping term with

a variable pick up, in this manner gives enhanced transient execution over the entire working extent. A. Jain, K. Joshi [6] presents about Voltage direction with STATCOMs: Modeling, control and results. This presents framework demonstrating and control plan for quick load voltage direction utilizing static compensators (STATCOMs). The displaying system gives a reasonable portrayal of load voltage size and STATCOM responsive current on a prompt premise. Direct and nonlinear controllers for the direction issue are outlined and thought about through recreation comes about. Inner progression of the STATCOM are demonstrated utilizing a similar procedure. Lyapunov based versatile controllers are intended for controlling the STATCOM receptive current while keeping up its dc transport voltage.

D. Soto and R. Pena [7] present about Nonlinear control procedures for fell multilevel STATCOMs. The procedures rely on upon the control capacity of the converter yield voltage and are appropriate for line recurrence exchanged converters. The principal procedure considers a STATCOM where the voltage is set autonomously of the dc interface voltage. Quick receptive power control inside sub process duration reaction is accomplished. The second methodology is compelled to a voltage whose abundance stays corresponding to the dc interface voltage.

G. E. Valdarannma, P. Mattavalli [8] presents about Reactive power and unbalance remuneration utilizing STATCOM with dissipativity based control. This approach depends on a recurrence space displaying of framework elements utilizing positive arrangement and negative succession dynamic parts. The latency based technique, a group of controllers is acquired whose goal is to manage unequal supply voltages, and to perform direction of AC lopsided streams.

C.Hochgraf and R.H.Lasseter,[9] presents about Statcom controls for operation with unequal voltages. In this paper, Statcom need to ready to deal with unequal voltages. A synchronous casing voltage controller is introduced that works notwithstanding when 3phase symmetry is lost. The proposed controller permits the statcom to ride through extreme transient irregularity without detaching from the power framework and to help with rebalancing voltages. The controller keeps up

adequate transmission capacity to perform glimmer remuneration.

Mr.M.ChinnaThimmaiah [11] Voltage dependability might be a fundamental idea in up the assurance and responsibleness of energy frameworks. The static compensator (STATCOM), a very much preferred gadget for receptive power administration upheld door side road (GTO) thyristors, has picked up a considerable measure of enthusiasm inside the most recent decade for up establishment stability[1]. inside the past, fluctuated administration ways are made arrangements for STATCOM administration. References [2]–[9] mainly work in the administration style as opposed to investigating an approach to set corresponding essential (PI) administration picks up. In a few STATCOM models, the administration rationale is authorized with the PI controllers. The administration parameters or increases play a key consider STATCOM execution. Directly, few examinations are dispensed inside the administration parameter settings. Inside the [10] PI controller picks up ar composed in an exceedingly free examination or experimentation approach with tradeoffs in execution and intensity.

3. ADAPTIVE PI CONTROL FOR STATCOM & FLOWCHART

The STATCOM with fixed PI control parameters may not reach the desired and acceptable response in the power system when the power system operating condition (e.g., loads or transmissions) changes. An adaptive PI control method is presented

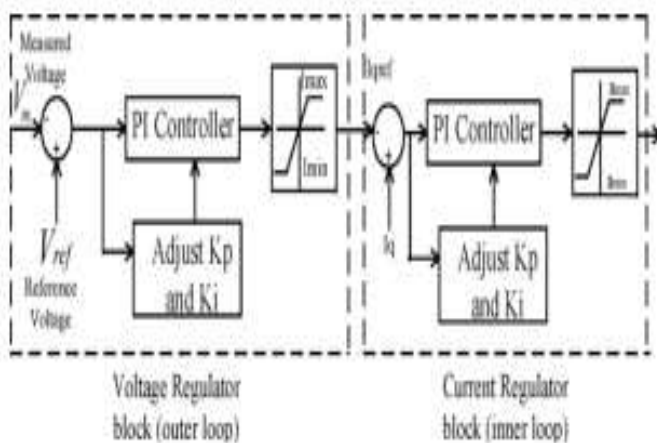

Fig. Adaptive PI control block for STATCOM. in this section in order to obtain the desired response and to avoid performing trial-and-error

studies to find the suitable parameters for PI controllers when a new STATCOM is installed in a power system. With this adaptive PI control method, the dynamical self-adjustment of PI control parameters can be realized. An adaptive PI control block for STATCOM is shown in Fig.. In Fig., the measured voltage and the reference voltage, and the x -axis reference current and the y -axis current are in per-unit values.

The proportional and integral parts of the voltage regulator gains are denoted by K_p and K_i , respectively. Similarly, the gains K_{p_c} and K_{i_c} represent the proportional and integral parts, respectively, of the current regulator. In this control system, the allowable voltage error is set to 0. The K_p and K_i can be set to an arbitrary initial value such as simply 1.0. One exemplary desired curve is an exponential curve in terms of voltage growth, shown in Fig. 4, which is set as the reference voltage in the outer loop. Other curves may also be used than the depicted exponential curve as long as the measured voltage returns to the desired steady-state voltage in the desired time duration. The process of the adaptive voltage-control method for STATCOM is described as follows.

- 1) The bus voltage is measured in real time.
- 2) When the measured bus voltage over time, the target steady-state voltage, which is set to 1.0 per unit (p.u.) in the discussion and examples, is compared with V_{ref} . Based on the desired reference voltage curve, K_p and K_i are dynamically adjusted in order to make the measured voltage match the desired reference voltage, and the x -axis reference current can be obtained.
- 3) In the inner loop, I_{ref} is compared with the x -axis current. Using a similar control method like the one for the outer loop, the parameters K_{p_c} and K_{i_c} can be adjusted based on the error. Then, a suitable angle can be found and eventually the dc voltage in STATCOM can be modified such that STATCOM provides the exact amount of the reactive power injected into the system to keep the bus voltage at the desired value. It should be noted that the current I_{ref} and the angle α are the limits imposed with the consideration of the maximum reactive power generation capability of the STATCOM controlled in this manner.

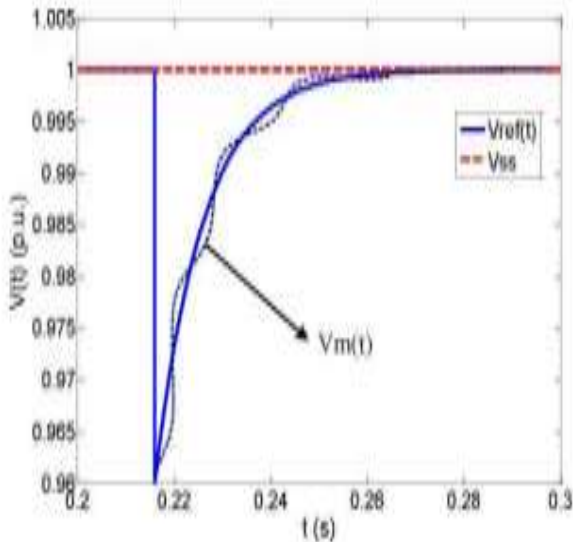

Fig.. Reference voltage curve.

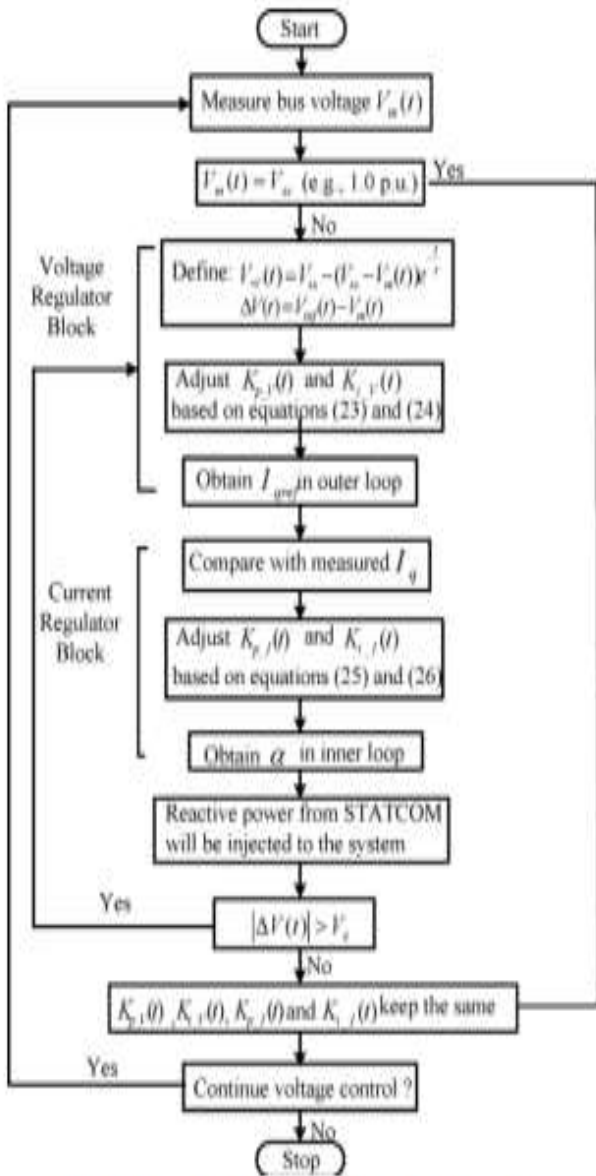

Fig.. Adaptive PI control algorithm flowchart.

If one of the maximum or minimum limits is reached, the maximum capability of the

STATCOM to inject reactive power is considered to have been reached. Certainly, as long as the STATCOM sizing has been appropriately studied during the planning stages for inserting the STATCOM into the power system, the STATCOM should not reach its limit unexpectedly. Fig. is an exemplary flowchart of the proposed adaptive PI control for STATCOM for the block diagram of Fig..The adaptive PI control process begins at Start. The bus voltage over time is sampled according to a desired sampling rate. Then, is compared with . If , then there is no reason to change any of the identified parameters and the power system is running smoothly.

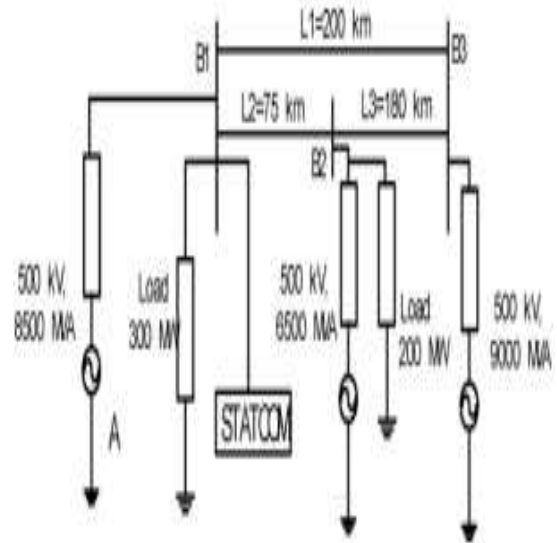

Fig.. Studied system.

blocks and the current regulator blocks are reentered until the change is less than the given threshold . Thus, the values for, and are maintained. If there is the need to continuously perform the voltage-control process, which is usually the case, then the process returns to the measured bus voltage. Otherwise, the voltage-control process stops .

ADAPTIVE PI CONTROL SCHEME

Adaptive Control covers a set of techniques which provide a systematic approach for automatic adjustment of controllers in real time, in order to achieve or to maintain a desired level of control system performance when the parameters of the plant dynamic model are unknown and/or change in time.

Now consider the case when the parameters of the dynamic model of the plant change unpredictably in time. These situations occur either because the environmental conditions change (ex: the

dynamical characteristics of a robot arm or of a mechanical transmission depend upon the load; in a DC-DC converter the dynamic characteristics depend upon the load) or because we have considered simplified linear models for nonlinear systems (a change in operation condition will lead to a different linearized model). These situations may also occur simply because the parameters of the system are slowly time-varying (in a wiring machine the inertia of the spool is time-varying). In order to achieve and to maintain an acceptable level of control system performance when large and unknown changes in model parameters occur, an adaptive control approach has to be considered. In such cases, the adaptation will operate most of the time and the term non-vanishing adaptation fully characterizes this type of operation (also called continuous adaptation).

Further insight into the operation of an adaptive control system can be gained if one considers the design and tuning procedure of the “good” controller illustrated in Fig.. In order to design and tune a good controller, one needs to:

The tuning of the controller will be done in real time from data collected in real time on the system. The corresponding adaptive control scheme is shown in Fig..

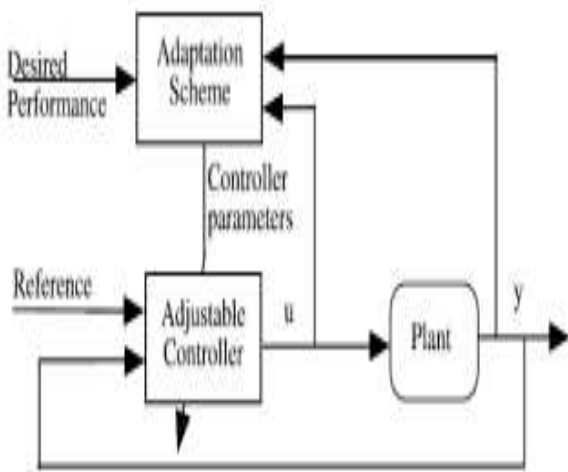

Fig. An adaptive control system

- 1) Specify the desired control loop performances.
- 2) Know the dynamic model of the plant to be controlled.
- 3) Possess a suitable controller design method making it possible to achieve the desired performance for the corresponding plant model.

The dynamic model of the plant can be identified from input/output plant measurements obtained under an experimental protocol in open or in closed loop. One can say that the design and tuning of the controller is done from data collected on the system. An adaptive control system can be viewed as an implementation of the above design and tuning procedure in real time.

4. SIMULATION RESULT

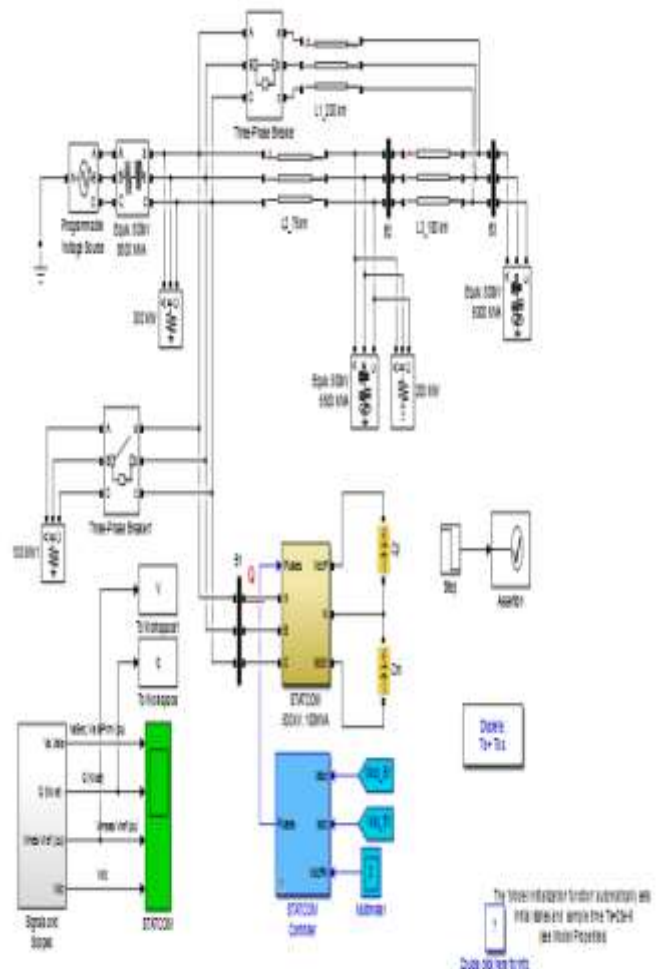

Fig 4.1 Simulation of STATCOM

(I) Response of the Original Model

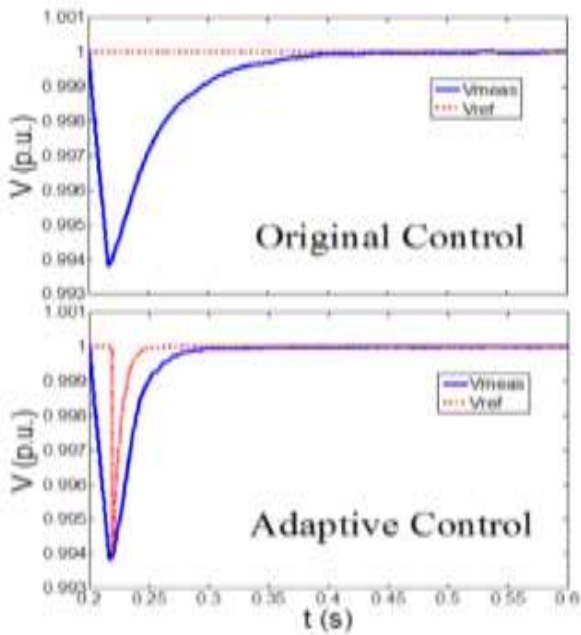

Fig.4.2 Results of the voltages using the same network and loads

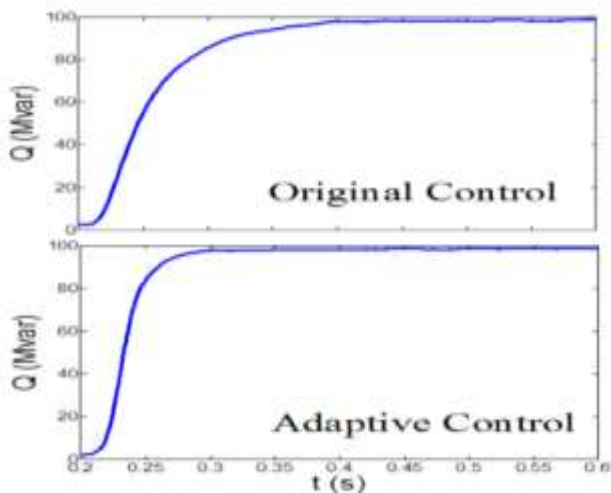

Fig.4.3 Results of the output reactive power

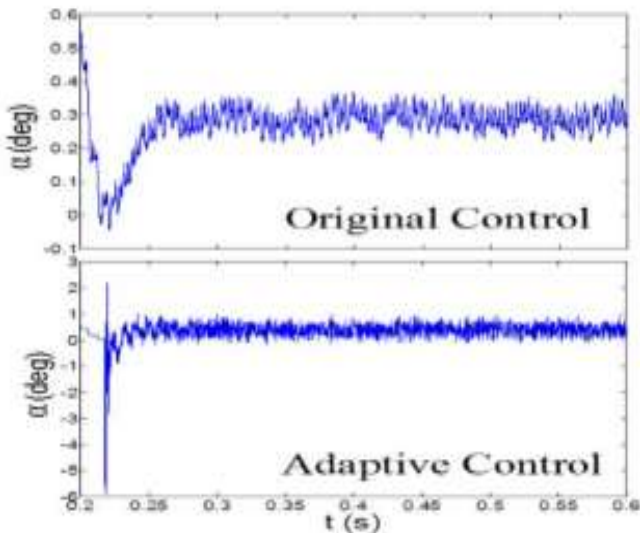

Fig.4.4 Results of α using the same network and loads.

	Original Ctrl.	Adaptive Ctrl.
Lowest Voltage after disturbance	0.9938 p.u.	0.9938 p.u.
Time (sec) when V=1.0	0.4095 sec	0.2983 sec
Δt to reach V=1.0	0.2095 sec	0.0983 sec
Var Amount at steady state	97.76 MVar	97.65 MVar
Time to reach steady state Var	0.4095 sec	0.2983 sec

Table 1 Performance comparison for the original system parameters

5. CONCLUSION AND FUTURE WORK

In the literature, various STATCOM control methods have been discussed including many applications of PI controllers. However, these previous works obtain the PI gains via a trial and-error approach or extensive studies with a tradeoff of performance and applicability. Hence, control parameters for the optimal performance at a given operating point may not always be effective at a different operating point. To address the challenge, this paper proposes a new control model based on adaptive PI control, which can self-adjust the control gains dynamically during disturbances so that the performance always matches a desired response, regardless of the change of operating condition. Since the adjustment is autonomous, this gives the “plug-and-play” capability for STATCOM operation. In the simulation study, the proposed adaptive PI control for STATCOM is compared with the conventional STATCOM control with pretended fixed PI gains to verify the advantages of the proposed method. The results show that the adaptive PI control gives consistently excellent performance under various operating conditions, such as different initial control gains, different

load levels, change of the transmission network, consecutive disturbances, and a severe disturbance. In contrast, the conventional STATCOM control with fixed PI gains has acceptable performance in the original system, but may not perform as efficient as the proposed control method when there is a change of system conditions.

Future work may lie in the investigation of multiple STATCOMs since the interaction among different STATCOMs may affect each other. Also, the extension to other power system control problems can be explored.

REFERENCES

- F. Li, J. D. Kueck, D. T. Rizy, and T. King, "A preliminary analysis of the economics of using distributed energy as a source of reactive power supply," Oak Ridge, TN, USA, First Quart. Rep. Fiscal Year, Apr. 2006, Oak Ridge Nat. Lab.
- Jain, K. Joshi, A. Behal, and N. Mohan, "Voltage regulation with STATCOMs: Modeling, control and results," IEEE Trans. Power Del., vol. 21, no. 2, pp. 726–735, Apr. 2006.
- D. Soto and R. Pena, "Nonlinear control strategies for cascaded multilevel STATCOMs," IEEE Trans. Power Del., vol. 19, no. 4, pp. 1919–1927, Oct. 2004.
- F. Liu, S. Mei, Q. Lu, Y. Ni, F. F. Wu, and A. Yokoyama, "The nonlinear internal control of STATCOM: Theory and application," Int. J. Elect. Power Energy Syst., vol. 25, no. 6, pp. 421–430, 2003.
- Hochgraf and R. H. Lasseter, "STATCOM controls for operation with unbalanced voltage," IEEE Trans. Power Del., vol. 13, no. 2, pp. 538–544, Apr. 1998.
- P. Kundur, "Power System Stability and Control", McGraw-Hill, 1994.
- Y.H. Song and A.T. Johns, "Flexible ac transmission systems (FACTS)", The Institute of Electrical Engineers, London, 1999.
- N.G. Hingorani and L. Gyugyi, "Understanding FACTS: concepts and technology of flexible ac transmission systems", IEEE Press, NY, 1999.
- Adaptive PI Control of STATCOM for Voltage Regulation, YaoXu, Student Member, IEEE, and Fangxing Li, Senior Member,

IEEE. IEEE TRANSACTIONS ON POWER DELIVERY, VOL. 29, NO. 3, JUNE 2014.

- H. Norouzi, A. M. Sharaf, "Two control schemes to enhance the dynamic performance of the STATCOM and SSSC," IEEE Trans. Power Del., vol. 20, no. 1, pp. 435–442, Jan. 2005.
- M. S. E. Moursi, A. M. Sharaf, "Novel controllers for the 48-pulse VSC STATCOM and SSSC for voltage regulation and reactive power compensation," IEEE Trans. Power Syst., vol. 20, no. 4, pp. 1985–1997, Nov. 2005.
- M. S. E. Moursi and A. M. Sharaf, "Novel controllers for the 48-pulse VSC STATCOM and SSSC for voltage regulation and reactive power compensation," IEEE Trans. Power Syst., vol. 20, no. 4, pp. 1985–1997, Nov. 2005.
- H.F. Wang, "Applications of damping torque analysis to statcom control", I. J. of Elec. Pwr& Energy Sys., vol. 22, pp. 197-204, 2000.
- H. Norouzi and A. M. Sharaf, "Two control schemes to enhance the dynamic performance of the STATCOM and SSSC," IEEE Trans. Power Del., vol. 20, no. 1, pp. 435–442, Jan. 2005.
- Schauder and H. Mehta, "Vector analysis and control of the advanced static VAR compensators," Proc. Inst. Elect. Eng., Gen., Transm., Distrib., vol. 140, no. 4, pp. 299–306, Jul. 1993.

Author's Profile:

[1]. **CHEEPURI RAVITEJA**, M.Tech Student, Department of EEE, Kakinada Institute of Technological Sciences (KITS), Ramachandrapuram.



[2]. **N.S.KALYAN CHAKRAVATHI**, B.E, M.TECH, he completed his BE in GITAM University and M.Tech in University College of Engineering Kakinada. and working as Associate Professor at Kakinada Institute of Technological

Juni Khyat

(UGC Care Group I Listed Journal)

Sciences (KITS), Ramachandrapuram. and he is
the Head of the EEE department in the college.

ISSN: 2278-4632

Vol-12 Issue-01 No.01: 2022