

Performance Analysis of Three Dissimilar Tube Bundles of Heat Exchanger

Biswajit Nayak¹, Binayak Das², Jitendra Barad³
^{1,2}Asst. Professor, ³Student
Department of Mechanical Engineering
Einstein Academy of Technology and Management
Bhubaneswar, Khurdha
Odisha, India

Abstract:- In this paper, performance analysis of three different tube bundles for particular heat exchanger and their comparison analysis is proposed. These three types are known as smooth, micro finned and corrugated tubes. Heat exchanger is designed with smooth tube bundle and then simulation is done. Micro Fin and corrugation over tube is used separately for same heat exchanger in feasible size and simulated for its performance. Also, performance analysis is done by comparing the heat transfer rate with pressure drop.

Keywords: Micro-Fin, Tube bundles, HX, tube, CFD, fin, corrugation.

I. INTRODUCTION

Heat exchangers are used in so many applications such as evaporator, radiator, condenser, cooler etc. These are all forms of heat exchanger. Most of industries are using heat exchangers. They are classified into many kinds but their purpose is to transfer heat between two mediums (fluids). Phase change also happens in heat exchanging process like evaporator and condenser. Performance of heat exchanger is based on many parameters. It is required to optimize parameters for enhancing heat transfer rate. In literatures, research over optimized parameters to particular heat exchanger design has been explored. It isn't saturated till now.

In present work, comparison of three different tube bundles for particular heat exchanger is proposed. Three types are smooth, micro finned and corrugated tubes. Heat exchanger will be designed with smooth tube bundle and simulated. Micro fin and corrugation over tube is applied separately for same heat exchanger in feasible size and simulated for performance. Besides, comparison is done with heat transfer rate and pressure drop.

2. LITERATURE REVIEW

Bhuiyan A.A. et al present numerical study of 3d thermal and hydraulic characteristics of wavy fin and tube heat exchanger. Numerical visualisations are used to study the thermal and hydraulic performance of four row wavy staggered fin and tube heat exchanger. In this paper, the

effects of tube arrangements, different geometrical parameters and inlet flow angles are investigated in terms of heat transfer and pressure drop and efficiency for the wavy fin-and-tube heat exchanger for turbulent flow regime using $k-\omega$ turbulence model with 5% turbulence intensity. The tube arrangement and the geometrical parameters such as pitch, wavy angle and inlet flow angle have strongly affected the flow structure. Comparatively higher heat transfer and pressure drop is found in staggered arrangement than in lined for both laminar and turbulent case. By increasing L_i and L_t , f and j both decreases as the flow becomes free and less compact. But efficiency goes high. The fin spacing very strongly influences the heat transfer and pressure drop. If it is too small, the effects are less; if it is too large, the effect is comparatively higher [1].

Digvijay S. et. al presents heat transfer analysis of a cone shaped helical coil heat exchanger. In this work, the experimental evaluation of cone shaped helical coil heat exchanger is carried out. The overall conclusions related to the comparative analysis between the cones shaped coil & simple helical coil are presented. It is found that the inner Nusselt number, Convective heat transfer coefficient and overall heat transfer coefficient increases when the coil side fluid flow rate increases. From comparative experimental analysis for the conical coil & simple helical coil it is found that the inner Nusselt number, convective heat transfer coefficient & overall heat transfer coefficient are higher in case of conical coil than that of simple helical coil. From comparative experimental analysis, it is found that the effectiveness of heat exchanger is on higher side in conical coil than that of simple helical coil. It was found that the heat transfer rates are 1.18 to 1.38 times more for the cone shaped helical coil than that of simple helical coil. In the present study an experimental investigation of heat transfer in cone shaped helical coil heat exchanger is reported for various Reynolds numbers [2].

Date P. et. al presents heat transfer enhancement in fin and tube heat exchanger. Heat exchangers have been widely used in the fields of refrigeration, air conditioning,

space heating and chemical engineering. Fin-tube heat exchanger with two rows of round tubes is widely used in air-conditioning and refrigeration systems to meet such demands as fan power saving and quietness. Traditional heat exchanger devices such as plate type, plate fin type and tubular type operate on the principle of temperature difference between two mediums and can realize efficient sensible heat transfer from one fluid to another. With the development of design of heat exchanger and making some changes without affecting the cost much the heat transfer enhancement can be achieved. One such novel approach is using punched winglet-type vortex generator in fin tube heat exchanger which is proved numerically that it enhance the heat transfer. Various type of possible and cost effective technique of the heat transfer enhancement were presented in this literature review. It is clear the vortex generator technique is one of the promising approaches of heat transfer enhancement. Lot of work been carried out on various designs and use of simulation software made it easier [3].

Jadhav A.D. et. al presents CFD analysis of shell and tube heat exchanger to study the effect of baffle cut on the pressure drop. Shell and tube heat exchangers are known as the work-horse of the chemical process industry when it comes to transferring heat. These devices are available in a wide range of configurations as defined by the Tubular Exchanger Manufacturers Association. The applications of single-phase shell-and-tube heat exchangers are quite large because these are widely in chemical, petroleum, power generation and process industries. In essence, a shell and tube exchanger is a pressure vessel with many tubes inside of it. One process fluids flows through the tubes of the exchanger while the other flows outside of the tubes within the shell. The tube side and shell side fluids are separated by a tube sheet. In these heat exchangers, one fluid flows through tubes while the other fluid flows in the shell across the tube bundle. The design of a heat exchanger requires a balanced approach between the thermal design and pressure drop. The performance parameters include heat transfer, pressure drop, effectiveness etc [4].

Lemouedda A. et. al presents numerical investigations for the optimization of serrated finned-tube heat exchangers. Due to the widespread utilization of heat exchangers in various daily and industrial applications, the improvement of their performances is of great importance. Usually, more attention and research efforts are devoted to regions where the energy-carrying fluid is a gas since gases have a very low thermal conductivity compared to liquids. Many passive techniques are used to enhance the heat transfer on the gas-side of heat exchangers. Helical serrated

finned-tubes are well established in many thermal systems. This paper presents the results of numerical calculations carried out for the performance improvement of these devices. The work is divided into three main investigations conducted for Reynolds numbers between $Re = 600$ and 2600 . The first investigation shows the effect of the fin serration, where a comparison between performances of finned tubes with and without fin serration is presented. Another main investigation is conducted on the effect of fin twisting of the outermost part of the fin on the performance of the serrated finned-tubes. Here, twisting angles considered are between $Deg = 0^\circ$ and 25° . The third investigation deals with the effect of the number of fin segments per period [5].

Murugesan M.P. et. al presents fouling of corrugated plate type heat exchanger in the dairy industry. Experiments were conducted in the corrugated plate type heat exchanger in the dairy industry. Although there is an established link between protein de-naturation and fouling, the relative impact of the denatured and aggregated proteins on the deposit formation is not clear. In general, it is believed that fouling is controlled by the aggregation reaction of proteins and the formation of protein aggregates reduces fouling. The mass transfer of proteins between the fluid and heat transfer surface also plays an important role. It may not be possible to completely eliminate fouling in heat exchangers simply due to the fact that de-naturation and aggregation reactions initiate as soon as milk is subjected to heating. Fouling, however, can be controlled and mitigated by selecting appropriate thermal and hydraulic conditions. But during the thermal treatment of such sensible fluids in a corrugated plate type heat exchanger, proteins are denaturized and aggregate reaction takes place. Finally formation of fouling affect's the treatments efficiency and overall heat transfer efficiency. In this present work fouling factors consider the change in a process condition. Preheating of test fluid and cleaning of corrugated plate surface provides controlling of fouling and enhances the rate of heat transfer and increase the treatment efficiency (pasteurization, sterilization process) of milk products. Plate Type Heat Exchangers have a number of applications in the pharmaceutical, petrochemical, chemical, power, and dairy, food & beverage industry. In the recent past plate type heat exchangers are commonly used when compared to other types of heat exchangers such as shell and tube type in the process of heat transfer. This is with respect to their compactness, ease of production, sensitivity and efficiency. Corrugated Plate type Heat Exchangers (PHEs) are very common in dairy industries [6].

Nikhil J. et. al presents heat transfer analysis of corrugated plate heat exchanger of different plate geometry. Plate Heat Exchangers have a number of applications in the pharmaceutical, petrochemical, chemical, power, and dairy, food & beverage industry. Recently, plate heat exchangers are commonly used when compared to other types of heat exchangers such as shell and tube type in heat transfer processes because of their compactness, ease of production, sensitivity, easy care after set-up and efficiency. Reynolds number is varied from about 500–2500. Based on the experimental data, a simplified Nusselt number correlation incorporating effects of Reynolds number, Prandtl number, viscosity variation and chevron angle trying to be propose. Different types of plates will also be tested and investigated using the set-up constructed. Based on the experimental results obtained from the set-up and the computational fluid dynamics analysis of the same cases, new correlations can be found for the different plate geometries to be tested and analyzed. With the result of new experiments, the selection program can also be extended for new type of plate geometries [7].

O' Zceyhan V. et. al presents heat transfer and thermal stress analysis in grooved tubes. Heat transfer and thermal stresses, induced by temperature differences in the internally grooved tubes of heat transfer equipment, have been analysed numerically. The analysis has been conducted for four different kinds of internally grooved tubes and three different mean inlet water velocities. Constant temperature was applied from the external surface of the tube. Energy and governing flow equations were solved using finite difference scheme. Finite element method (FEM) was used to compute the thermal stress fields. Grooving effects on the thermal stress ratio have been discussed. In general, the maximum thermal stresses (MX) occur near the grooved parts of the tubes for all water inlet velocities because of the higher temperature gradient; thermal stress increases when the volume flow rate of the fluid increases. Maximum thermal stress ratios have occurred in $p = d$ cases for 0.5 m/s mean water inlet velocity. Consequently, location of the maximum and minimum stress ratios inside the tube depends on the distance between two grooves, and the volume flow rate of the fluid. The types of grooves and the distance between them must be considered to avoid thermal stress effects inside the tube, and/or surface modifications must be applied to surfaces where the maximum thermal stresses occur. This study provides ideas on the design of new heat exchangers using grooved surfaces for heat transfer augmentation [8].

Parmar K.S. et. al presents Enhancement of heat transfer rate of finned tube heat exchanger. Heat

exchangers are popular used in industrial and engineering applications. The design procedure of heat exchangers is quite complicated, as it needs exact analysis of heat transfer rate, efficiency and pressure drop apart from issues such as long-term performance and the economic aspect of the equipment. Whenever inserts technologies are used for the heat transfer enhancement, along with the improvement in the heat transfer rate, the pressure drop also increases, which induces the higher pumping cost. Therefore any augmentation device or methods utilized into the heat exchanger should be optimized between the benefits of heat transfer coefficient and the higher pumping cost owing to Round Tubular type heat Exchanger will used to transfer the heat from Surrounding to the System or the increased frictional losses. Fins are used to transfer better heat transfer rate between fluid to fluid and system to surrounding. Fins used to absorb or reject the heat with higher rate of heat transfer. This type of heat exchangers used in condenser, Evaporator, Solar Flat plate absorber, etc. Heat exchangers are popular used in industrial and engineering applications. The design procedure of heat exchangers is quite complicated, as it needs exact analysis of heat transfer rate, efficiency and pressure drop apart from issues such as long-term performance and the economic aspect of the equipment. Whenever inserts technologies are used for the heat transfer enhancement, along with the improvement in the heat transfer rate, the pressure drop also increases, which induces the higher pumping cost. Therefore any augmentation device or methods utilized into the heat exchanger should be optimized between the benefits of heat transfer coefficient and the higher pumping cost owing to the increased frictional losses. So, if we provided fins rectangular or circular type on internal periphery of the tube type heat exchanger than the heat transfer rate will going to be increased [9].

Pandey S.D. et. al presents experimental investigation of heat transfer and friction factor in a corrugated plate heat exchanger. Experiments are conducted to determine the heat transfer characteristics for fully developed flow of air and water flowing in alternate corrugated ducts with an inter-wall spacing equal to the corrugation height. The friction factor is found for air channel. The test section was formed by three identical corrugated channels having corrugation angle of 30° with cold air flowing in the middle one and hot water equally divided in the adjacent channels. Sinusoidal wavy arcs connected with tangential flat portions make the said corrugation angle with transverse direction. The Reynolds number based on hydraulic diameter varied from 750 to 3200 for water and from 16900 to 68000 for air by changing the mass flow rates of the two fluids. The Prandtl

numbers were approximately constant at 2.55 for water and 0.7 for air. The various correlations are obtained $Num=0.247Re^{0.83}$ for water, $Num=66.686Re^{0.18}$ and friction factor $f = 0.644 / Re^{0.18}$ for air ^[10].

Patel S. et. al presents computational modelling of STHE. Shell and tube heat exchangers consist of a bundle of parallel tubes that provide the heat transfer surface separating the two fluid streams. The tube side fluid passes axially through the inside of the tubes. The shell side fluid passes over the outside of the tubes. The process fluid is usually placed inside the tubes for ease of cleaning or to take advantage of the higher pressure capability inside the tubes. The thermal performance of such an exchanger usually surpasses a coil type but is less than a plate type. The system under study is often a complex nonlinear system for which simple, intuitive analytical solutions are not readily available. Rather than deriving a mathematical analytical solution to the problem, experimentation with the model is done by adjusting the parameters of the system in the computer, and studying the differences in the outcome of the experiments. Operation theories of the model can be derived/deduced from these computational experiments. The computational modelling involves pre-processing, solving and post-processing. The flow and temperature fields inside the shell are studied using non-commercial computational fluid dynamics software tool ANSYS CFX 14.0. From the computational fluid dynamics simulation results, the shell side outlet temperature, pressure drop, recirculation near the baffles, optimal mass flow rate and heat transfer graph, mass and momentum graph, turbulence graph are determined for the given heat exchanger geometry. Shell and tube heat exchanger for shell side study of the fluid flow with zero baffle inclination angles is modelled in the Pro-E Software. The initial CFD analysis has been performed in the ANSYS Software. The $k-\epsilon$ turbulence model is used for the simulation based on the literature survey. The initial simulation results agree with the fundamental physics of the heat transfer in the heat exchanger ^[11].

Pengcheng X. et. al presents experimental study of heat transfer enhancement and friction loss induced by inserted rotor-assembled strand. The heat transfer enhancement and flow friction in a rotor-assembled strand inserted tube were measured in the flow of water. The Prandtl number of the working fluids varied from 5.64 to 5.80, and the Reynolds numbers ranged from 10600 to 36200. Fixed mounts were used in the validation experiment to eliminate fixed mounts' entrance effect. Analysis of the heat transfer coefficient and friction factor characteristics, as well as the regression analysis of the dependence of the Nusselt number and friction factor on

Prandtl number and Reynolds number showed as follows. The measured data of inserted tube reveal that rotor-assembled strand can significantly improve heat transfer with the Nusselt number increased by 101.6%-106.6% and the overall heat transfer coefficient increased by 58.1%-67.4% within the Reynolds number range of 20000 to 36000. Meanwhile, friction factor increases by 52.2%-84.2% within the same Reynolds number range. The correlations of Nusselt number and friction factor as function of the Reynolds number and Prandtl number were determined through multi variant linear normal regression ^[12].

Sheu W.H.T. et. al presents a comparison study on fin surfaces in finned-tube heat exchangers. Finned tube heat exchangers have been used for heat transfer between gas and solid phases for many years. No attempt will be made to justify whether tubes arranged in a two row staggered configuration, positioned with equilateral triangular centres, are superior to other combinations. The flow pattern observed in the plate and tube heat exchanger configuration can be very complex due to the three-dimensional helical horseshoe vortices and flow separations. Analyses can be further complicated by the added complexities of extended surfaces. In the past decade, little progress has been made in measuring the local heat transfer coefficient because "no experimental method exists that allows measurement of the conjugate local heat transfer of a finned-tube element" (Fiebig et al., 1995a; b). With the advent of high speed computers and ever-improving numerical analyses, it is now possible to numerically predict the heat transfer characteristics in a three-dimensional context. In this study, we exploited the computational fluid dynamics technique to assess the transfer capabilities of two classes of fin surfaces. Their capabilities, as a whole, can be presented in terms of some parameters. The span-averaged Nusselt number and pressure drop are among those parameters addressed in this article ^[13].

Shirgire N.D et. al presents review on comparative study between helical coil and straight tube heat exchanger. Heat exchangers are used in a wide variety of applications including power plants, nuclear reactors, refrigeration and air-conditioning systems, automotive industries, heat recovery systems, chemical processing, and food industries. Besides the performance of the heat exchanger being improved, the heat transfer enhancement enables the size of the heat exchanger to be considerably decreased. In general, the enhancement techniques can be divided into two groups: active and passive techniques. The active techniques require external forces like fluid vibration, electric field, and surface vibration. The passive techniques

require special surface geometries or fluid additives like various tube inserts. Both techniques have been widely used to improve heat transfer performance of heat exchangers. The centrifugal force due to the curvature of the tube results in the secondary flow development which enhances the heat transfer rate. This phenomenon can be beneficial especially in laminar flow regime. Thermal performance and pressure drop of a shell and helically coiled tube heat exchanger with and without helical crimped fins have been investigated by Naphon one of the most frequent uses of helically coiled tubes is in shell and coiled tube heat exchangers. Going through the existing literature, it was revealed that there are a few investigations on the heat transfer coefficients of this kind of heat exchangers considering the geometrical effects like coil pitch. Also, this scarcity is more prominent for shell-side heat transfer coefficients [14].

Shrirao P.N. et. al presents convective heat transfer analysis in a circular tube with different types of internal threads of constant pitch. Experimental investigations of heat transfer, friction factor and thermal enhancement factor of a plain circular tube and a circular tube with three different types of internal threads viz. acme, buttress and knuckle threads of constant pitch are described in the present report. This work presents an experimental study on the mean Nusselt number, friction factor and thermal enhancement factor characteristics in a circular tube with different types of internal threads of 120 mm pitch under uniform wall heat flux boundary conditions. In the experiments, measured data are taken at Reynolds number in range of 7,000 to 14,000 with air as the test fluid. The experiments were conducted on circular tube with three different types of internal threads viz. acme, buttress and knuckle threads of constant pitch. The heat transfer and friction factor data obtained is compared with the data obtained from a plain circular tube under similar geometric and flow conditions. The variations of heat transfer and pressure loss in the form of Nusselt number (Nu) and friction factor (f) respectively is determined and depicted graphically. It is observed that at all Reynolds number, the Nusselt number and thermal performance increases for a circular tube with buttress threads as compared with a circular tube with acme and knuckle threads. These are because of increase in strength and intensity of vortices ejected from the buttress threads [15].

Sudharsan M. et. al presents flow and heat transfer for flow past elliptic tubes in fin-tube heat exchangers. The flow and temperature fields past elliptic tubes are in general complex, since they depend on the tube shape, flow, thermal and other factors. The flow and heat transfer characteristics have been investigated by developing a

three-dimensional computational code based on SIMPLE algorithm using finite volume technique to solve the conservation equations of mass, momentum and energy. A body-fitted, multi-block structured grid capable of accommodating different tube shapes has been generated. The results show that the elliptic tube shows better combined thermal-hydraulic characteristics compared to circular tube due to the streamlined surface of the elliptic tube. A finite volume based numerical investigation has been carried out to study the flow and heat transfer for flow past circular and elliptical tubes confined in a rectangular channel. For performance comparison of flow past various tube aspect ratios, it is worthwhile to consider time-averaged flow and temperature fields over a fixed interval of time. Even though the time averaged fields do not exactly correspond to a particular instantaneous field, time-averaged fields display overall flow characteristics. Hence, in this study, the flow and temperature field data correspond to their time-averaged values. The results show that the increase in aspect ratio leads to decrease in pressure drop. However, the effect of aspect ratio on heat transfer is found to be marginal [16].

Thantharate V. et. al presents experimental and numerical comparison of heat transfer performance of twisted tube and plain tube heat exchangers. In heat exchangers the primary focus is to maximize heat transfer rate, reduce exchanger size and reduce pumping power. In view of this various active and passive techniques have been used over plain tubes. Twisted tube is a passive technique. Presently twisted tubes are limited to shell and tube type long and straight passage applications. The main aim of this study is to compare the performance of plain tube heat exchanger with twisted tube heat exchanger on various aspects to determine its feasibility for use in applications like automobile radiators, air conditioners or similar type of multi pass applications. In the present work, an experimental study of the heat transfer performance of plain tube and twisted tube for multi pass heat exchanger has been carried out and compared with each other. Analytical study has also been done to get the experimental and Numerical values verified. For determination of pressure drop analytical calculations are done. Tube and Duct type of cross flow heat exchanger was employed. Reynolds number range is from 600 to 7000 covering laminar and turbulent range [17].

Wei L. et. al presents flow mechanism and heat transfer enhancement in longitudinal-flow tube bundle of shell-and-tube heat exchanger. Under the guidance of the principle of heat transfer enhancement in the core flow, and with the analysis of the disturbance mechanism of longitudinal flow, a new type of high efficiency and low

resistance heat ex-changer with rod-vane compound baffle was designed and investigated numerically. The results show that for the same heat transfer coefficient, flow resistance in the shell side of rod-vane compound baffle heat exchanger is smaller than that of rod baffle heat exchanger. And for the same flow resistance, heat transfer performance of the former is better than that of the latter

[18].

3. MATERIALS AND DESIGN OVERVIEW

3.1 Material Selection

To be able to transfer heat well, the tube material should have good thermal conductivity. Because heat is transferred from a hot to a cold side through the tubes, there is a temperature difference through the width of the tubes. Because of the tendency of the tube material to thermally expand differently at various temperatures, thermal stresses occur during operation. This is in addition to any stress from high pressures from the fluids themselves. The tube material also should be compatible with both the shell and tube side fluids for long periods under the operating conditions (temperatures, pressures, pH, etc.) to minimize deterioration such as corrosion.

Two fluids, of different starting temperatures, flow through the heat exchanger. One flows through the tubes (the tube side) and the other flows outside the tubes but inside the shell (the shell side). Heat is transferred from one fluid to the other through the tube walls, either from tube side to shell side or vice versa. The fluids can be either liquids or gases on either the shell or the tube side. In order to transfer heat efficiently, a large heat transfer area should be used, leading to the use of many tubes. In this way, waste heat can be put to use. This is an efficient way to conserve energy.

Heat exchangers with only one phase (liquid or gas) on each side can be called one-phase or single-phase heat exchangers. Two-phase heat exchangers can be used to heat a liquid to boil it into a gas (vapor), sometimes called boilers, or cool a vapor to condense it into a liquid (called condensers), with the phase change usually occurring on the shell side. Boilers in steam engine locomotives are typically large, usually cylindrically-shaped shell-and-tube heat exchangers. In large power plants with steam-driven turbines, shell-and-tube surface condensers are used to condense the exhaust steam exiting the turbine into condensate water which is recycled back to be turned into steam in the steam generator.

All of these requirements call for careful selection of strong, thermally-conductive, corrosion-resistant, high quality tube materials, typically metals, including copper alloy, stainless steel, carbon steel, non-ferrous copper alloy, Inconel, nickel, Hast alloy and titanium. Poor choice of tube material could result in a leak through a tube between the shell and tube sides causing fluid cross-contamination and possibly loss of pressure.

The simple design of a shell and tube heat exchanger makes it an ideal cooling solution for a wide variety of applications. One of the most common applications is the cooling of hydraulic fluid and oil in engines, transmissions and hydraulic power packs. With the right choice of materials they can also be used to cool or heat other mediums, such as swimming pool water or charge air. One of the big advantages of using a shell and tube heat exchanger is that they are often easy to service, particularly with models where a floating tube bundle (where the tube plates are not welded to the outer shell) is available.

3.2 Proposed Tube Types

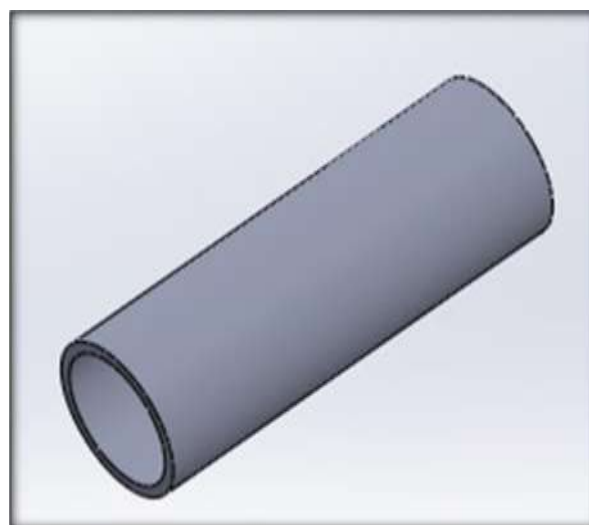

Fig. 3.1: Smooth Tube

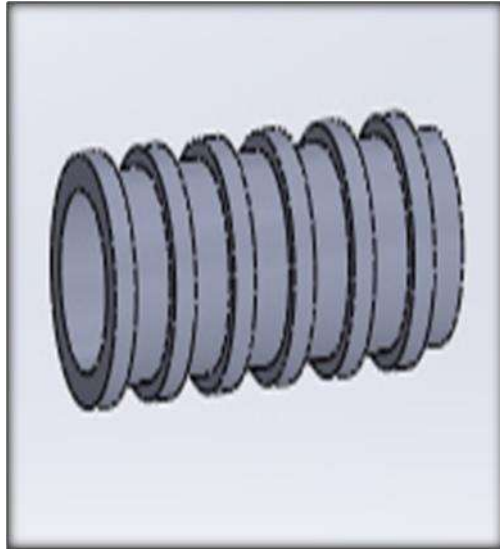

Fig. 3.2: Micro-fin Tube



Fig. 3.3: Corrugated Tubes

3.3 Design Requirement and Fluids

The following features are requirements of HX to be designed. Table contains fluid properties and requirements.

Table 3.1: Requirement and Properties

	Hot fluid	Cold fluid
Type	Transformer oil	Water
Specific heat capacity	2.13 KJ/Kg.K	4.12 KJ/Kg.K
Side	Shell	Tube
Inlet temperature	363K	302K
Outlet temperature	343K	305.6K (found from calculations)
Density	890 Kg / m ³	1000 Kg / m ³
Viscosity	0.650 N.s / m ²	0.000798 N.s / m ²
Mass flow rate	4.5 Kg / s	10 Kg / s

4. SIMULATION RESULTS AND DISCUSSION

4.1 Simulation Results and Discussion:

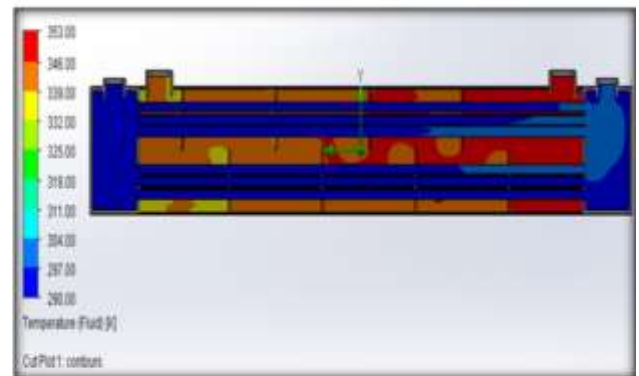

Fig.4.1: Temperature Plot of Smooth Tube HX

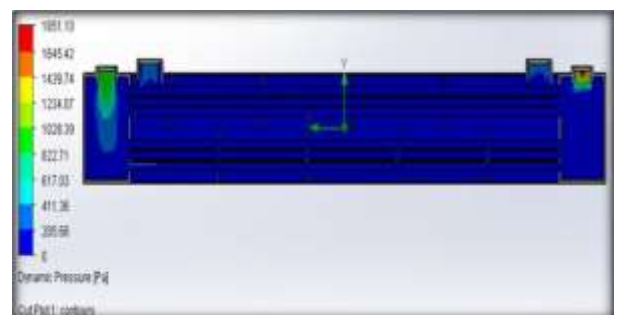

Fig. 4.2: Dynamic Pressure Plot of Smooth Tube HX

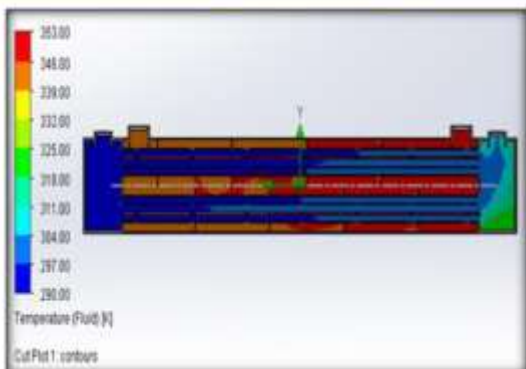

Fig. 4.3: Temperature Plot of Finned Tube HX

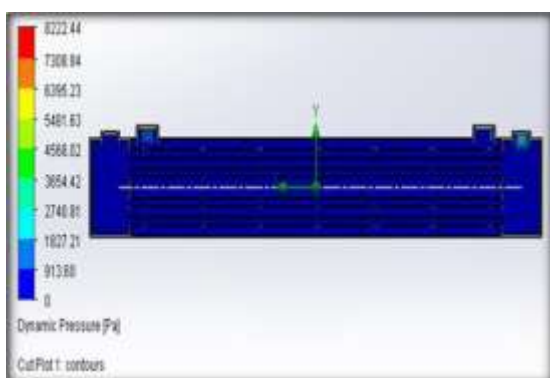

Fig. 4.4: Dynamic Pressure Plot of Finned Tube HX

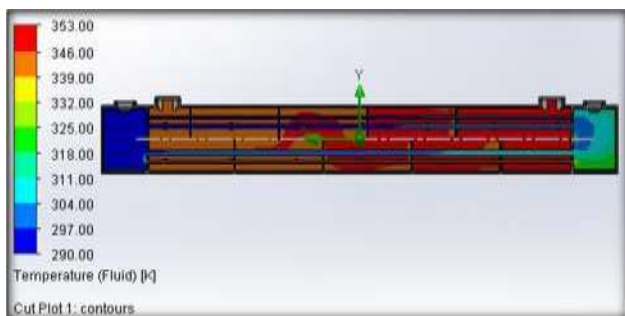

Fig. 4.5: Temperature Plot of Corrugated Tube HX

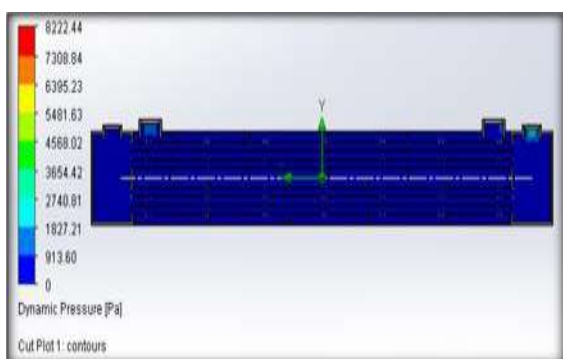

Fig. 4.6: Dynamic Pressure Plot of Corrugated Tube HX

Table 4.1: Outlet Temperature

Required Value	Smooth Tube	Finned Tube	Corrugated Tube
343 K	343.57 K	342 K	339.56 K

Table 4.2: Pressure Drop

Smooth Tube	Finned Tube	Corrugated Tube
1161.36 Pa	24284.23 Pa	36353.64 Pa

Effectiveness is defined by ratio of actual heat transfer to maximum possible heat transfer. Here, the purpose is reducing heat of hot water. Heat dissipated from hot water is calculated for effectiveness. $[Q = m_h * C_{ph} * (T_{hi} - T_{ho})]$

Table 4.3: Effectiveness

Smooth Tube	Finned Tube	Corrugated Tube
0.97	1.1	1.34

Table 4.2 shows pressure drop across shell side of each heat exchangers. Corrugated type gives more pressure drop. In this case, smooth tube is better than others. In effectiveness point of view, corrugated tube is better than others. Although effectiveness more than 1 isn't possible in practical case, corrugation will give more effectiveness. Due to more pressure drop, structural consideration is important. Flow induced vibrations may affect structure severely. This will be future work extended from our work.

5. CONCLUSION

Comparison of three different tube bundles for particular heat exchanger is proposed. Heat exchanger is designed with smooth tube bundle and simulated. Micro fin

and corrugation over tube is applied separately for same heat exchanger. Besides, comparison is done between three configurations for heat transfer rate. Corrugated type gives more pressure drop. In this case, smooth tube is better than others. In effectiveness point of view, corrugated tube is better than others. Although effectiveness more than 1 isn't possible in practical case, corrugation will give more effectiveness. Due to more pressure drop, structural consideration is important. Flow induced vibrations may affect structure severely. This will be future work extended from our work.

17. Thantharate V. et. al (2013) 'Experimental and Numerical Comparison of Heat Transfer Performance of Twisted Tube and Plain Tube Heat Exchangers', International Journal of Scientific & Engineering Research, Volume 4, Issue 7.
18. Wei L. et. al (2009) 'Flow mechanism and heat transfer enhancement in longitudinal-flow tube bundle of shell-and-tube heat exchanger', Science in China Series E: Technological Sciences, Springer.

REFERENCES

1. Bhuiyan A.A. et. al (2012) 'Numerical Study Of 3d Thermal And Hydraulic Characteristics Of Wavy Fin And Tube Heat Exchanger', Frontiers in Heat and Mass Transfer, DOI: 10.5098/hmt.v3.3.3006.
2. Digvijay S. et. al (2013) 'Heat Transfer Analysis of a Cone Shaped Helical Coil Heat Exchanger', International Journal of Innovations in Engineering and Technology, Vol. 3 Issue 1.
3. Date P. et. al (2013) 'Heat Transfer Enhancement In Fin And Tube Heat Exchanger - A Review', ARPN Journal of Engineering and Applied Sciences Vol. 8, No. 3.
4. Jadhav A.D. et. al (2014) 'CFD Analysis of Shell and Tube Heat Exchanger to Study the Effect of Baffle Cut on the Pressure Drop', International Journal of Research In Aeronautical And Mechanical Engineering Vol.2 Issue.7, pg 1-7.
5. Lemouedda A. et. al (2011) 'Numerical investigations for the optimization of serratedfinned-tube heat exchangers', Applied Thermal Engineering Vol 31, pg 8-9.
6. Murugesan M.P. et. al (2013) 'To Study the Fouling of Corrugated Plate Type Heat Exchanger in the Dairy Industry', Research Journal of Engineering Sciences Vol. 2(1), pg 5-10.
7. Nikhil J. et. al (2012) 'Heat Transfer Analysis of Corrugated Plate Heat Exchanger of Different Plate Geometry: A Review', International Journal of Emerging Technology and Advanced Engineering Vol 2, Issue 10.
8. O' ZCEYHAN V. et. al (2005) 'Heat transfer and thermal stress analysis in grooved tubes', Sadhana Vol. 30, Part 4, pp. 537-553.
9. Parmar K.S. et. al (2014) 'Enhance the Heat Transfer Rate of Finned Tube Heat Exchanger: A Review', International Journal on Recent and Innovation Trends in Computing and Communication ISSN: 2321-8169 Volume, 2 Issue: 3 441 - 446 .
10. Pandey S.D. et. al (2011) 'Experimental investigation of heat transfer and friction factor in a corrugated plate heat exchanger', international journal of energy and environment, Volume 2, Issue 2, 2011 pp.287-296.
11. Patel S. et. al (2014) 'Computational Modeling of STHE', International Journal of Engineering Science and Innovative Technology, Volume 3, Issue 2.
12. Pengcheng X. et. al (2008) 'Experimental Study of Heat Transfer Enhancement and Friction Loss Induced by Inserted Rotor-assembled Strand (I) Water', Chinese Journal of Chemical Engineering, 16(6), pg 849-855.
13. Sheu T.W.H. et. al (1997) 'A comparison study on fin surfaces in finned-tube heat exchangers', International Journal of Numerical Methods for Heat & Fluid Flow, Vol. 9 No. 1, pp. 92-106.
14. Shirgire N.D. et. al (2013) 'Review on Comparative Study between Helical Coil and Straight Tube Heat Exchanger', Journal of Mechanical and Civil Engineering Volume 8, Issue 2, PP 55-59.
15. Shrirao P.N. et. al (2013) 'Convective Heat Transfer Analysis in a Circular Tube with Different Types of Internal Threads of Constant Pitch', International Journal of Engineering and Advanced Technology Volume-2, Issue-3.
16. Sudharsan M. et. al (2010) 'Flow And Heat Transfer For Flow Past Elliptic Tubes In Fin-Tube Heat Exchangers', the 37th National & 4th International Conference on Fluid Mechanics and Fluid Power.