

# **A consumer-based approach to the design of distributed energy systems with solar photovoltaic generation**

**YARRAMSETTI DINEESHA<sup>1</sup>, G. RAMESH BABU<sup>2</sup>**

<sup>1</sup> **PG Research scholar**, Department of ECE, Jogaiah Institute Of Technology And Sciences college Of Engineering, Palakol, West Godavari. A.P.

<sup>2</sup> **Research Supervisor & Assistant professor**, Department of ECE, Jogaiah Institute Of Technology And Sciences college Of Engineering, Palakol, West Godavari. A.P.

-----\*\*\*-----

*Abstract -- System simulation is necessary to investigate the feasibility of Solar PV system at a given location. This study is done to evaluate the feasibility of grid connected rooftop solar photovoltaic system for a Jogaiah Institute Of Technology And Sciences college Of Engineering, Palakol, West Godavari. A.P.). This paper is aimed at simulation and development of Solar PV system for grid connected and stand-alone system on the basics of module, losses, and total produces energy, size and shadow analysis.*

*Index Terms— Solar PV Module, Grid-Connected Inverter, Grid-Connected PV System, modeling tools, PVSYST.*

## **I. INTRODUCTION**

The study growth of photovoltaic, an average about 45% annual increase is noticed during the years 2000 to 2009. From the study of cost economics of a solar photovoltaic power plant, PV modules cost about 45% and the other 55% is due to components, like inverters, cables, transformers and civil works. This work aims at solving this problem by introducing novel approach to arrange the solar panels in a way that minimizes the use of floor space and maximize the power generation.

## **III. LITERATURE RVIEW**

Energy is a vital requirement to sustain and improve the standard of our daily lives. With the exponential growth in population, rapid spread of technology and advancement of globalization, energy consumption in the developing countries like India, is rising at a very fast pace. Like many of the developing countries, India is also facing an immense shortage of energy.

The electricity sector in India had an installed capacity of Peak power deficit in the country fell to 5.4% at 7,556 megawatts (MW) in April from 7.4% a year ago due to increased capacity and lower electricity consumption by the country. The decline in consumption in certain north Indian states was due to a weak intra-state network for dissemination of electricity. According to the latest data by the Central Electricity Authority (CEA), the total requirement in the country last consumption was 2, 49,998 MW, as against the supply of 2, 42,442 MW a peak power deficit of 5.4% [1]. This shortfall necessitates load shedding. Suffering of the common people is nowhere more pronounced than in urban areas where electricity is a necessity in carrying out daily activities. Like most other places, solar energy has the promise and potential to solve the energy crisis of India as it is available throughout the country. It is projected that by the year 2030, the solar PV electricity will also dominate compared to other sources of energy At the core of any PV system simulation model is the model on an individual PV cell. Which describes the relationship between the current and voltage generated by a PV cell. A search of the literature has been performed to Grid connected system. D. Sharma et al.

[7] shown grid connected systems generate clean electricity near the point of use, without the transmission and distribution losses or the need for the batteries. Stand-alone system involves no interaction with a utility grid. Climate and energy performance of technical shelter in different conditions. C.P. Kandalama et al. Concluded that the simulation of a grid-connected solar photovoltaic system with the use of the computer software package PV system and their performance was evaluated. K. Maharaja et al. Has investigated the sizing of the solar power plant in standalone mode of operation. Based on the load survey and the utilization factor, the capacity of the plant is determined for battery sizing and PV sizing. PVSYST are used for the sizing of the solar PV power plant. S. Jacques et al. described a new, highly modular simulation tool named "PVLab" and developed by the GREMAN laboratory. It is designed to assist the designer in the sizing of PV (photovoltaic) installations. Jaydeep V. Rumelia concluded that the simulation of a grid-connected solar photovoltaic system using of the computer software package Pvsyst and their performance was evaluated. Jones K. Chacko et al. Investigated the major factors which affect the performance of

the solar PV module three different them panel arrangement that will minimize the PV loss due to temperature and maximize power generation. By literature review it is clear that a comparative study of different thermal parameter and PV system needed for efficient use of PV systems.

### III. METHODOLOGY

The basic characteristics of a solar panel will depends upon type of solar cell, temperature of the cell and the radiations incident on it. The conversion efficiency of PV system is important factor to be determined in the power generation technologies. In this paper we used to analysis the performance with the help of PVSYST software.

PVSYST software is used to design different types of solar application systems like DC grid, grid connected, standalone and DC pumping systems. Different solar PV module, battery and converter manufacture database for designing the system as it is included in the software package. Location details for the area of the experiment can be added with the help of software like NASA-SSE satellite data, Metronome, RETSCREEN etc. This software helps to design the system with respect to the load and available area. It also helps to analyze the annual, monthly and weekly production and performance of the designed system

PVSYST is designed to be used by architects, engineer, and researchers. It is also a very useful educative tool. It includes a detailed contextual help menu that explains the procedures and models that are used, and offers a user-friendly approach with guide to develop a project. PVSYST is able to import meteor data from many different sources, as well as personal data.

#### A. Grid Connected System

The Grid Connected system consisting of a solar PV module, a charge controller. In some cases extra diesel generator back up is used and it will be depends upon the type and behavior of the load. In Grid Connected system, solar PV modules generates the current and it helps to meet the load demand during daytime. At the same time, some generated current is used to charge the battery and it is helpful to meet the load demand during night time. Charge controllers are used to control the flow of charging and discharging current into and from the battery. Figure 1. Shows the block diagram of Grid Connected PV system.

Operation: - Residential, grid-connected rooftop systems which have a capacity more than 100 kilowatts can meet the load of most consumers. They can feed excess power to the grid where it is consumed by other users. The feedback is done through a meter to monitor power

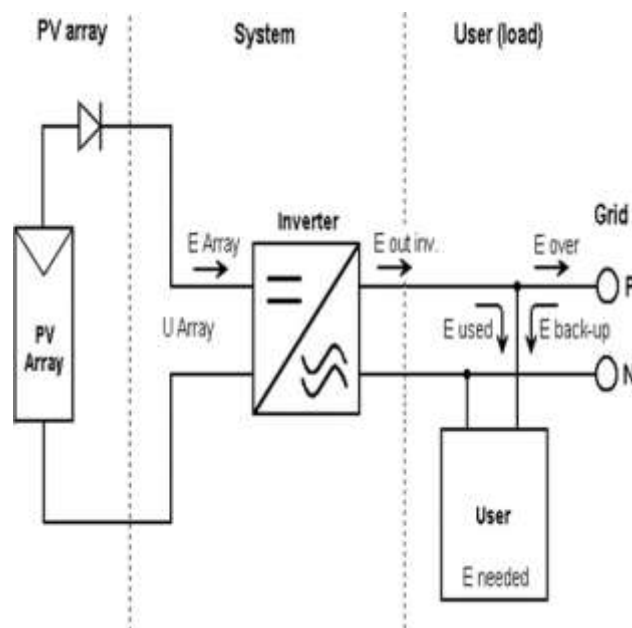

Figure 1. Block Diagram of Grid Connected PV system.

Photovoltaic wattage may be less than average consumption, in which case the consumer will continue to purchase grid energy, but a lesser amount than previously. If photovoltaic wattage substantially exceeds average consumption, the energy produced by the panels will be much in excess of the demand. In this case, the excess power can yield revenue by selling it to the grid. Depending on their agreement with their local grid energy company, the consumer only needs to pay the cost of electricity consumed less the value of electricity generated. This will be a negative number if more electricity is generated than consumed. Additionally, in some cases, cash incentives are paid from the grid operator to the consumer. Connection of the photovoltaic power system can be done only through an interconnection agreement between the consumer and the utility company. The agreement details the various safety standards to be followed during the connection.

#### B. Stand –Alone System

Stand-alone PV systems are designed to operate independent of the electric utility grid, and are generally designed and sized to supply certain DC and/or AC electrical loads. Common applications are direct power to DC loads, water pumping and telecommunications. With an inverter it can also power AC load. For systems with no battery the energy is used immediately; only works when it's sunny. Components are Modules, charge controller, batteries, and may or may not have an inverter which converts DC power to A/c power.

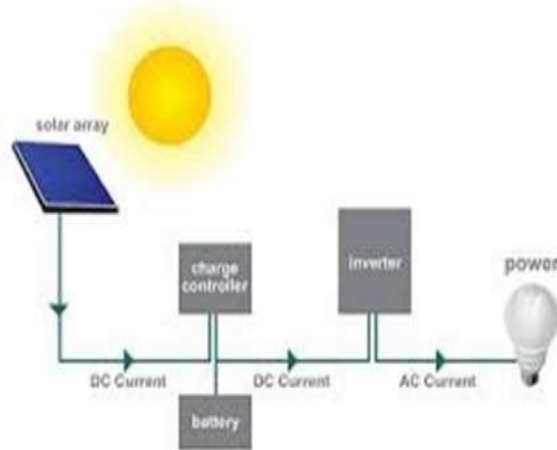

Figure 2. Block Diagram of stand Alone System

#### IV. TECHNICAL SPECIFICATION

Data Specification of the system:- Grid connected photovoltaic system for 100kWp power plant is simulated with the help of PVSYST software. The Geographical site selected is Surat and data of this site lies on 21.17° N latitude and 72.83° E longitude, 20° tilt, 0° Azimuth, 14 meters above sea level (i.e. Altitude is 14 m). From the simulation it was found that 399 module and 25kWac inverters are required in which Single Solar Panel Output is 250Wp. 21 PV modules are connected into series and 19 string of 21 PV models are used in the system. Required area for plant installation will be 649 m<sup>2</sup>. At the maximum power point, current and voltage of the system will be about 156 A, 573V respectively. The output of the PV system depends upon the received solar radiation and temperature.

#### V. COMPARISON OF DIFFERENT SOLAR PARAMETER

Although the study clearly demonstrate the maximum energy generation for the 100 KWp solar panel system as

compared to different phases, like normalized production, performance ratio, efficiency and one should be careful about the PV loss due to temperature for such a system.

**CASE 1 (free mounted module with air circulation)**

The first case we were considered is a standard technical specifications as well as Free mounted module with air circulation. In this case, high amount of radiation of about 2011.5 kW/m<sup>2</sup> energy is received on the PV array in a year. By the proposed grid connected system 176.81 MW electricity will be generated out of that 170.23 MW electricity is available to the grid. 170.23 MW electricity will be supply to the grid throughout the year. Figure 3. Shows the Performance ratio, nominal energy and monthly & yearly data of 100KW grid connected system (case 1). From the simulation it is found that performance ratio (PR) of the system is 82.44%. Here, the maximum PR is 80.5% in the month of January and minimum in the month of April (80.1%). System will produce 4.68 Wh/kWp/day electricity that is available to the grid. In which Global radiation is maximum on the March (204.2kW/m<sup>2</sup>/month) and minimum on July (123.1kW/m<sup>2</sup>/month) and also maximum electricity is produced on the March (17.56 MW/month) and minimum on July (11.07 MW/month).

**SYSTEM LOSSES:** - PV system is not able to convert 100% energy received from the solar radiation because of various losses Figure 4. Represents detailed losses occur in the proposed grid connected PV system. Firstly about 1908 kWh/m<sup>2</sup> radiation is incident on the solar panels. Maximum losses takes place during PV array electric production. The module efficiency has been 15.46 % at the STC. By this, 201.8 MWh/year electricity will be produced by the PV array. After that PV losses due to irradiance, PV losses due to temperature, module quality loss, module array mismatch loss, wiring losses and Inverter losses, approximately 170.2MWh/yr of electricity is available to the grid. From figure 4 it is concluded that the maximum efficiency of the output array is 15.04% in the month of January and minimum in the month of April 14.27%.

**VI. SITE DETEILE**

The Latitude of poornima college Jaipur Rajasthan is 26.7678. The Longitude of poornima college Jaipur Rajasthan is 75.8503. The Latitude and Longitude of Poornima College Jaipur Rajasthan is 26.7678 and 75.8503 respectively. 26.7678 Latitude and 75.8503 Longitude can be mapped to closest address of Poornima Institute of Engineering and Technology, Poornima Marg, Sitapura, Jaipur, Rajasthan 302022, India.

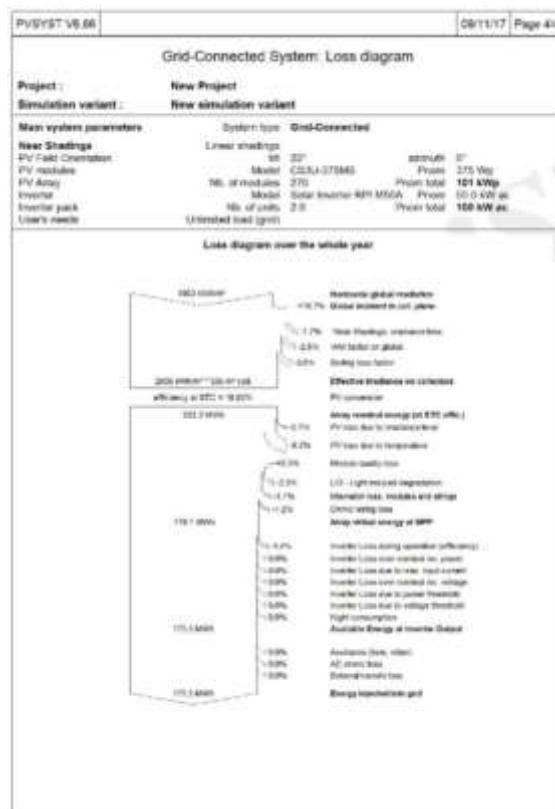

Table 2: Loss diagram and efficiency of array of 100KW grid connected system

## VII. RESULTS

Simulated as well as experimental results of performance assessment, yield forecasting and loss forecasting for installed 100 kWp grid connected solar photovoltaic system at Poornima university have been obtained, The results obtained from forecasting simulation as well as recorded value for April month have been summarized in tabular form. Table explains the result obtain for four parameters from simulation whereas Table is the Summary of recorded data from data logger of sunny web box.

Name of Parameters	Yearly Average Forecasted Value
PR	80.14%
Produced Energy(MWH/year)	176.6
Specific Proceed (KWH/KWp/year)	1733
Energy Into Grid (MWH)	175.5

Table 3: Shading Analysis for PV System

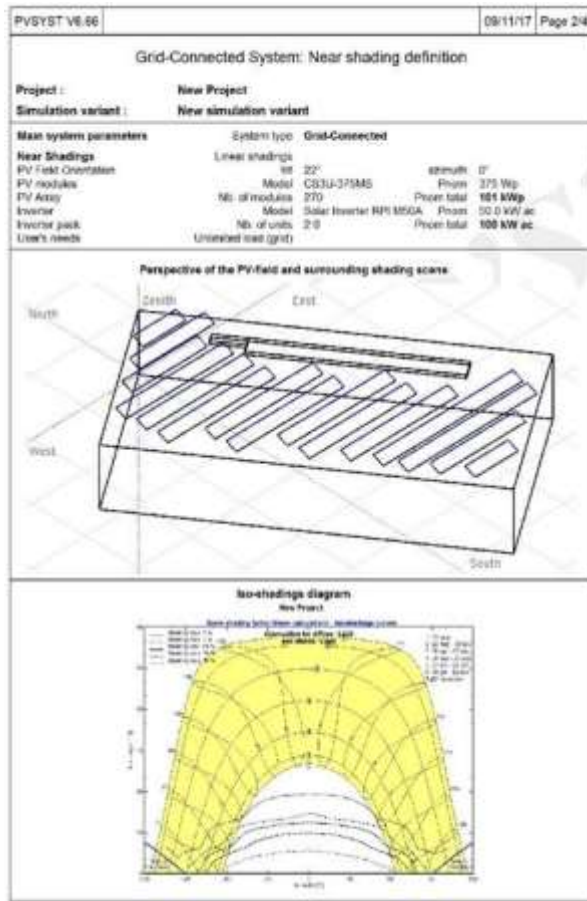

### VIII. CONCLUSION

Electricity generation has now become a major challenge for a country like India with rising fuel price and worsening air pollution. Generating electricity using PV panels is a potential solution to the current energy crisis faced by India as it is renewable and climate friendly.

By the help of PVSYS software PV system configuration, output electricity and system losses are analyzed. The whole study is focused to design a grid connected photovoltaic system for climatic conditions of Surat, Gujarat, India. For design of this system suitable PV mode and inverter are selected. It is founded that 399 PV panels of 250Wp single solar panel output and inverter of 25kWac are the optimal solution for supplying the load of grid throughout the year. From the proposed system with free mounted air

circulation, semi-integrated with air duct behind and integration with fully insulated back have been 170.23MWh, 163.11MWh and 155.20MWh electricity generated in a year and it will be available to the grid. Performance ratio of the system is about 82.44%, 78.99% and 75.16% respectively.

#### REFERENCES

- [1] Sujain Kumar, Deepika Chauhan, Devendra Kumar Doda “A Comparative Analysis of Different Thermal Parameter Arrangements with Silicon Polycrystalline using PVSYSY” in International Journal of Engineering and Applied Sciences (IJEAS) ISSN: 2394-3661, Volume-4, Issue-7, July 2017
- [2] Chih-Lung Shen \*Cheng-Tao Tsai Yu-En Wu Chun-Chuan Chen” A Modified-Forward Multi-input Power Converter for Solar Energy and Wind Power Generation” in PEDS2009.
- [3] Hossein Mohammadian Foroushani , Mohammad Mohammadrezaei Seyed Mohammad Madani “A Single-Stage Three-Phase Grid-Connected Photovoltaic System With Fast Grid Voltage Regulation” in 30th Power System Conference (PSC2015), 23-25 November 2015, Niroo Research Institute, Tehran, Iran.
- [4] Arun Kumar Nayak1, Parag Sharma2, Suraj Kumar Jangid3” Performance analysis of solar photovoltaic system installed in Poornima University, Jaipur,Rajasthan” In National Conference on “RENEWABLE ENERGY AND ENERGY CONSERVATION (NCREEC-2016)” at Poornima University, Jaipur during May 20-21, 2016.
- [5] Kartika Dubey, M.T.Shah” DESIGN AND SIMULATION OF SOLAR PV SYSTEM” in 2016 International Conference on Automatic Control and Dynamic Optimization Techniques (ICACDOT) International Institute of Information Technology (I<sup>2</sup>IT), Pune
- [6] L. Palma\* Department of Electrical Engineering, Universidad de Concepcion, Edmundo Larenas 219 Concepcion, (Chile) “Design and Sizing of Short Term Energy Storage for a PV System” in 978-1-5090-4682-9/17/\$31.00 ©2017 IEEE.
- [7] Ganesh Baliram Ingale, Subhransu Padhee, Umesh C. Pati “Design of stand-alone sPV system for DC-micro grid” in 978-1-4673-9925-8/16/\$31.00 ©2016 IEEE
- [8] Victor Ayon, Matthew Robinso and Andrea Mammoli Victor Ayon, Matthew Robinson and Andrea Mammoli “Integration of Bottom-up Statistical Models of Loads on a Residential Feeder with the GridLAB-D Distribution System Simulator, and Applications” in 978-1-5386-1953-7/17/\$31.00 2017 IEEE.
- [9] Ashish Raj 1, Manoj Gupta 2, Sampurna Panda “Design Simulation and Performance Assessment of Yield and Loss Forecasting for 100 KWp Grid Connected Solar PV System” in 2016 2nd International Conference on Next Generation Computing Technologies (NGCT-2016) Dehradun, India 14-16 October 2016
- [10] Mr. S. Sheik Mohammed, Dr. D. Devaraj “Simulation and Analysis of Stand-alone Photovoltaic System with Boost Converter using MATLAB/Simulink” in 2014 International Conference on Circuit, Power and Computing Technologies [ICCPCT].
- [11] Sam Jose and Dr. Raieshwari L Itagi “Smart solar power plant” in IEEE ICCSP 2015 conference.
- [12] Mahmud Wasfi, Senior Member, IEEE “Solar Energy and Photovoltaic Systems” in Cyber Journals: Multidisciplinary Journals in Science and Technology, Journal of Selected Areas in Renewable and Sustainable Energy (JRSE), February Edition, 2011
- [13] Md Wazedur Rahman, Md Sultan Mahmud, Md Wazedur Rahman, Md Sultan Mahmud “Solar Lanes and Floating Solar PV” in International Conference on Innovations in Power and Advanced Computing Technologies [i-PACT2017].
- [14] José G. Hernández-Travieso, Carlos M. Travieso & Jesús B. Alonso , Malay Kishore Dutta “Solar Radiation Modelling for the Estimation of the Solar Energy Generation” in International Conference on Innovations in Power and Advanced Computing Technologies [i-PACT2017].
- [15] Christian Viehweger, Benedict Hartmann, Thomas Keutel, Olfa Kanoun Technische Universitaet Chemnitz, Germany christian.viehweger@etit.tu-chemnitz.de “Simulation of Shading Effects on the Power.